



CATALOG - 2017



LED LIGHTING
EQUIPMENT MANUFACTURER

VERSION - 7.5

Table of Contents

Click on each item to jump to that page (PDF version only)

◆ About Us	02
◆ Leds Don't Burn Out	03
◆ Turtle Friendly Lamps	05
◆ Low Bay/Garage Lights	07
◆ Gas Station	12
◆ Bay Lights	15
◆ Bay Lights/Flood Lights/Sports Lights	17
◆ Linear High Bays	20
◆ Wall Packs	23
◆ Flood Lights	27
◆ Corn Lights	29
◆ Post/Garden Lights	41
◆ Post Top Lights	42
◆ Street Lights	43
◆ Retrofit Lamps	46
◆ Spot Lights	57
◆ Bulkhead Lights	59
◆ Down Lights	60
◆ Plug-in Lights	63
◆ High Lumen Bulbs	66
◆ Tube & Panel Lights	68
◆ Pool Lights	74
◆ Accessories	78

About Us

EXXON Lighting Corporation was created to bring the most advanced LED lighting technology to municipal, commercial and industrial environments. Our executive team has 30+ years each working with engineering, research & development, overseas and US manufacturing, testing, QC and industry approvals. We are dedicated to using the latest technologies, producing the most reliable LED products in the most efficient manner.

EXXON Lighting products are being installed all over the world and are designed for thousands of applications. Our products are primarily produced overseas while our goals include bringing manufacturing to the USA and continuing our growth and dedication to the LED Lighting industry.

Our sales channel is through authorized electrical/lighting wholesale distributors.

We have programs designed to help distributors stock more of the right products for their customer base, marketing and sales tools to help create more opportunities and pricing that is second to none to help our loyal customers excel in the world of LED.



Leds Don't Burn Out

LEDs last considerably longer than incandescent or fluorescent lighting. don't burn out like traditional lighting, but rather gradually decrease in light output.

Useful Life

Their "useful life" is defined by the Alliance for Solid-State Illumination Systems and Technologies (ASSIST) as the time it takes until 70% of initial light output is reached, often 50,000 hours. They are resistant to thermal and vibrational shocks and perform well when subjected to frequent on-off cycling.

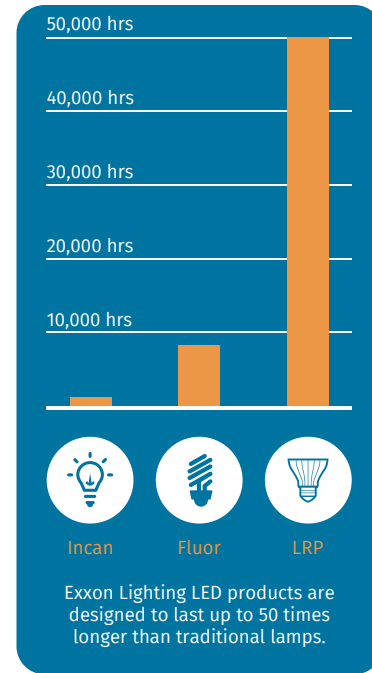

Benefits/Costs

LED lamps have many advantages over traditional lighting methods. These include:

- ⇒ **Low energy consumption** – retrofit bulbs are available to cover most applications
- ⇒ **Long service life** – LED bulbs can last 50,000 Plus
- ⇒ **Durable** – LED bulbs are resistant to thermal and vibrational shocks and turn on instantly from -40°C to 185°C, making them ideal for applications subject to frequent on-off cycling, such as garages, basements, refrigeration and cold rooms, sports lighting, etc.
- ⇒ **Directional distribution of light** – good for lighting up specific areas
- ⇒ **No infrared or ultraviolet radiation** – excellent for outdoor use because UV light attracts bugs
- ⇒ **Safety and environmentally conscious** – LEDs contain no mercury and remain cool to the touch
- ⇒ **Fully dimmable** – LEDs do not change their color tint when dimmed unlike incandescent lamps that turn yellow. **Note that not all LED lamps are designed to dim.**
- ⇒ **No frequency interference** – no ballast to interfere with radio and television signals
- ⇒ **Range of color** – LEDs can be manufactured to produce all colors of the spectrum without filters, they can also produce white light in a variety of color temperatures



You May Never Change Another Bulb

LED Lighting products are designed to last 50,000 hours or longer. Incredible longevity means that you might never change another bulb again.

Light for Life

What is 50,000 hours? It is 50 times the life of a typical incandescent bulb and 5 times the lifetime of an average compact fluorescent lamp (CFL). In fact, if you ran one lamp for 6 hours per day every day, it would last for nearly 23 years. That is five presidential elections, time for a home remodeling, and the life of an entire generation.

Maintenance Savings

We all have at least one bulb that is hard to reach and needs a ladder or a pole to replace it. For a home owner, fifty times longer life than incandescent bulbs means 50 fewer chances to fall off a ladder. For a business owner, it means significantly lower maintenance and labor expenses.

Waste Reduction

The production and use of LEDs requires significantly less energy than incandescent or CFLs. With LED Lighting products, you'll throw away fewer lamps and stop worrying about their mercury content. Almost all LED Lighting products are free of mercury and other toxic materials, a clear win for the environment.

Turtle Friendly Lamps

3W LED Amber 120V E26	
Lumens: 82.6	Fixture Color:
Watts: 3	Lifetime (Hours): 25,000
Light Color (Kelvin): Amber 625nm (Turtle friendly)	Master Carton Quantity:
	Master Carton Size:
Voltage: 120V AC	Master Carton Weight:
Base Type: E26 Medium	Warranty (Years): 3
Size in Inches:	Luminous efficacy: 31.27
Size in mm:	Working Temperature: Minimum -4 (-20)
CRI (Ra): >12	
Beam Angle: 200°	Certification: UL, cUL, RoHS
IP rating:	Net Weight:
Power Factor (PF): >0.98	Notes:

Item Code: BLB-40395



12W 1900K Corn Light E26 Medium Base Turtle Friendly UL	
Lumens:	Master Carton Size: 18.12" x
Watts: 12	14.17" x 9.45" (460mm x 360mm
Light Color (Kelvin): 1900 (590nm)	x 240mm)
Voltage: 100-277V AC	Master Carton Wgt: 11.88 lbs (5.4 kg)
Base Type: E26 Medium	LED Type: Epistar 3528 x 136
Size in Inches: 6.5 x 2.76	Power Factor: >0.9
Size in mm: 165 x 70	Fixture Material: Aluminum/PC
CRI (Ra):	Warranty (Years): 5
Beam Angle: 360°	Working Temperature °F (°C): -20 to
IP rating: 64	+140 (-29 to +60)
Fixture Color: White/Silver	Net Weight: 0.70 lbs (320 g)
Lifetime (Hours): >50,000	Compares to: 50WMMH, 50WHPS,
Master Carton Quantity: 12	50WHID
<p>Notes: Turtle Friendly Lamp. All recommendations are subject to individual configurations which affect final results. This statement does not take into account the variance of ceiling height, cone angle, Kelvin and many other factors.) No Fan - Rated for Enclosed Fixtures.</p>	

Item Code: CNL-51246



EXXON Lighting Corporation



Turtle Friendly Lamps

40W 1900K Corn Light "Turtle Friendly" 180° E26 M Base UL	
Lumens: 5400	Master Carton Quantity: 12
Watts: 40	Master Carton Size: 18.12" x 14.17" x 9.45" (460mm x 360mm x 240mm)
Light Color (Kelvin): 1900 590nm	Master Carton Wgt: 11.88 lbs (5.4 kg)
Voltage: 100-277V AC	Power Factor: >0.9
Base Type: E26 Medium	Fixture Material: Aluminum/PC
Size in Inches: 6.5 x 2.76	Warranty (Years): 5
Size in mm: 165 x 7	Working Temperature: -20 to +140 (-29 to +60)
CRI (Ra):	Certification: UL, CE, RoHS
Beam Angle: 180°	Net Weight: 0.70 lbs (317 g)
IP rating: 64	Compare to: 175WMH, 175WHPS, 175WHID
Power Factor (PF): >0.98	Notes: Turtle Friendly Light
Fixture Color: N/A	
Lifetime (Hours): >50,000	

Item Code: CNL-54019



Compares to a 75W MH/HPS/HID, 40W CFL



Their survival depends on us

Low Bay/Garage Lights

Available in a variety of configurations, wattages, lumens and colors (Kelvin)

60W 6000 LUMENS 6000K Low Bay UL/DLC

Lumens: 6000	Fixture Color: Black/Clear
Watts: 60	Fixture Material:
Light Color (Kelvin): 6000	Lifetime (Hours):
Voltage: 90-277V AC	Master Carton Quantity: 1
Base Type: 3 Wire	Master Carton Size:
Size in Inches: 8.9 x 12.32 x 12.32	Master Carton Weight:
Size in mm: 313 x 313 x 226	Warranty (Years): 5
CRI (Ra): 82	Luminous efficacy:
LED Type: SMD 5630 LEDs (176 pieces)	Working Temperature:
Beam Angle: 120°	Certification: UL, DLC
IP rating: 65	Net Weight:
Power Factor (PF):	Notes: 2700K/4000K available.
	Typical application: Garage Lights.

Item Code: **BYL-21783**



Compares to a 175W MH/HPS, 100W CFL

60W 5100 LUMENS 5500K Low Bay UL/DLC

Lumens: 5100	Fixture Color: Black/White
Watts: 60	Fixture Material: Aluminum/PC
Light Color (Kelvin): 5500	Lifetime (Hours): >50,000
Voltage: 100-277V AC	Master Carton Quantity: 1
Base Type: N/A	Master Carton Size: 16.15" x 16.15"
Size in Inches: 14.57 x 10.67	x 12.6" (410 x 410 x 320mm)
Size in mm: 370 x 271	Master Carton Weight:
CRI (Ra): >75	Warranty (Years): 5
LED Type: Philips	Luminous efficacy:
Beam Angle: 160°	Working Temperature: -22°F to +104°F (-30°C to +40°C)
IP rating: 54	Certification: UL, CE, DLC
Power Factor (PF): >0.95	Net Weight: 6.6 lbs (3 kg)
	Notes: Typical application: Garage Lights.

Item Code: **BYL-52461**



Compares to a 175W MH/HPS/HID

EXXON Lighting Corporation



Low Bay/Garage Lights

Available in a variety of configurations, wattages, lumens and colors (Kelvin)

80W 8000 LUMENS 5500K Low Bay ETL/CE	
Lumens: 8000	Fixture Color: Black/Opaque
Watts: 80	Fixture Material: Aluminum/PC
Light Color (Kelvin): 5500	Lifetime (Hours): >50,000
Voltage: 100-277V AC	Master Carton Quantity: 1
Base Type: N/A	Master Carton Size: 16.7" x 15.9"
Size in Inches: 12.4 x 12.4 x 9.05	x 11.8" (425 x 405 x 300mm)
Size in mm: 315 x 315 x 230	Master Carton Weight: 9.9 lb (4.5kg)
CRI (Ra): >85	Warranty (Years): 5
LED Type: Samsung 5630	Luminous efficacy: 100 lm/W
Beam Angle: 120°	Working Temperature: -40° F to
IP rating: 64	+113° F (-40° C to +45° C)
Power Factor (PF): >0.95	Certification: ETL, CE, RoHS
	Net Weight: 9.9 lbs (4.5 kg)
	Notes: Compares to a 250W MH/ HPS, 125W CFL.
	Typical application: Garage Lights.

Item Code: **BYL-58064**



Compares to a 250W MH/HPS/HID,
125W CFL



Low Bay/Garage Lights

20W 3300 LUMENS 4500K Corn Light E26 Medium Base

Lumens: 3300	Fixture Color: White
Watts: 20	Fixture Material: Aluminum/PC
Light Color (Kelvin): 4500	Lifetime (Hours): 50,000
Voltage: 100-277V AC	Master Carton Quantity: 10
Base Type: E26 Medium (E39 available)	Master Carton Size: 22" x 17" x 15.35" (56mm x 43mm x 39mm)
Size in Inches: 5 x 5.6	Master Carton Weight: 13.3 lbs (6 kg)
Size in mm: 127 x 142	Warranty (Years): 5
CRI (Ra): >80	Luminous efficacy: 165 lm/W
LED Type: Epistar 2835	Working Temperature: -22° F to +122° F (-30° C to +50° C)
Beam Angle: 180°	
IP rating: 44	Certification: UL, CE, RoHS
Power Factor (PF): >0.98	Net Weight: 1lb 2oz (510 g)
	Notes: Suitable for use in enclosed luminaires. No Fan.

Item Code: CNL-62004



Compares to a 75W MH/HPS/HID,
40W CFL

30W 4900 LUMENS 4500K Corn Light E26 Medium Base

Lumens: 4900	Fixture Color: White
Watts: 30	Fixture Material: Aluminum/PC
Light Color (Kelvin): 4500	Lifetime (Hours): 50,000
Voltage: 100-277V AC	Master Carton Quantity: 10
Base Type: E26 Medium (E39 available)	Master Carton Size: 22" x 17" x 15.35" (56mm x 43mm x 39mm)
Size in Inches: 5 x 5.6	Master Carton Weight: 13.3 lbs (6 kg)
Size in mm: 127 x 142	Warranty (Years): 5
CRI (Ra): >80	Luminous efficacy: 163 lm/W
LED Type: Epistar 2835	Working Temperature: -22° F to +122° F (-30° C to +50° C)
Beam Angle: 180°	
IP rating: 44	Certification: UL, CE, RoHS
Power Factor (PF): >0.98	Net Weight: 1lb 2oz (510 g)
	Notes: Suitable for use in enclosed luminaires. No Fan.

Item Code: CNL-63004



Compares to a 100W MH/HPS/HID,
50W CFL

EXXON Lighting Corporation



Low Bay/Garage Lights

40W 6200 LUMENS 4500K Corn Light E26 Medium Base	
Lumens: 6200	Fixture Color: White
Watts: 40	Fixture Material: Aluminum/PC
Light Color (Kelvin): 4500	Lifetime (Hours): 50,000
Voltage: 100-277V AC	Master Carton Quantity: 10
Base Type: E26 Medium (E39 available)	Master Carton Size: 22" x 17" x 15.35" (56mm x 43mm x 39mm)
Size in Inches: 5 x 5.6	Master Carton Weight: 13.3 lbs (6kg)
Size in mm: 127 x 142	Warranty (Years): 5
CRI (Ra): >80	Luminous efficacy: 155 lm/W
LED Type: Epistar 2835	Working Temperature: -22° F to +122° F (-30° C to +50° C)
Beam Angle: 180°	
IP rating: 44	Certification: UL, CE, RoHS
Power Factor (PF): >0.98	Net Weight: 1lb 2oz (510 g)
	Notes: Suitable for use in enclosed luminaires. No Fan.

Item Code: **CNL-64004**



Compares to a 175W MH/HPS, 75W CFL

50W 7600 LUMENS 4500K Corn Light E26 Medium Base	
Lumens: 7600	Fixture Color: White
Watts: 50	Fixture Material: Aluminum/PC
Light Color (Kelvin): 4500	Lifetime (Hours): 50,000
Voltage: 100-277V AC	Master Carton Quantity: 10
Base Type: E26 Medium (E39 available)	Master Carton Size: 22" x 17" x 15.35" (56mm x 43mm x 39mm)
Size in Inches: 5 x 5.6	Master Carton Weight: 13.3 lbs (6 kg)
Size in mm: 127 x 142	Warranty (Years): 5
CRI (Ra): >80	Luminous efficacy: 152 lm/W
LED Type: Epistar 2835	Working Temperature: -22° F to +122° F (-30° C to +50° C)
Beam Angle: 180°	
IP rating: 44	Certification: UL, CE, RoHS
Power Factor (PF): >0.98	Net Weight: 1lb 2oz (510 g)
	Notes: Suitable for use in enclosed luminaires. No Fan.

Item Code: **CNL-65004**



Compares to a 175W MH/HPS, 100W CFL

Low Bay/Garage Lights

60W 9100 LUMENS 4500K Corn Light E26 Medium Base

Lumens: 9100	Fixture Color: White
Watts: 60	Fixture Material: Aluminum/PC
Light Color (Kelvin): 4500	Lifetime (Hours): 50,000
Voltage: 100-277V AC	Master Carton Quantity: 10
Base Type: E26 Medium (E39 available)	Master Carton Size: 22" x 17" x 15.35" (56mm x 43mm x 39mm)
Size in Inches: 5 x 5.6	Master Carton Weight: 13.3 lbs (6 kg)
Size in mm: 127 x 142	Warranty (Years): 5
CRI (Ra): >80	Luminous efficacy: 160 lm/W
LED Type: Epistar 2835	Working Temperature: -22° F to +122° F (-30° C to +50° C)
Beam Angle: 180°	
IP rating: 44	Certification: UL, CE, RoHS
Power Factor (PF): >0.98	Net Weight: 1lb 2oz (510 g)
	Notes: Suitable for use in enclosed luminaires. No Fan.

Item Code: CNL-65004



Compares to a 225W-250W MH/HPS,
120W CFL

EXXON Lighting Corporation



Sales@exxonlighting.com



To TOC



LED Canopy Light

P/N : GSL-70452-0X

Note : Ceiling Mounting or Threaded Rod Mounting available to order.

Advantage :

- UL cUL DLC certificate
- IP65 Internal driver, Input voltage 100-277Vac
- No UV or IR in the beam
- Easy to install and operate
- Energy saving, Long lifespan
- Instant start, NO flickering, NO humming
- Green and eco-friendly without mercury

Application :

- Gas station

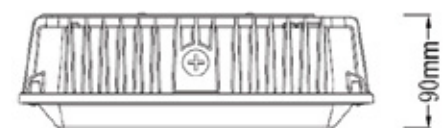
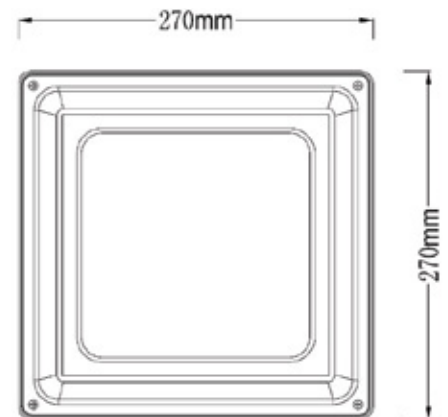



LED Canopy Light

P/N: GSL-71302-0X

Note: The Letter X in P/N stands for Kelvin.

Advantage :

- PHILIPS Chip, high CRI
- Mean Well IP65 driver, input voltage 100-277VAC
- No UV or IR in the beam
- Easy to install and operate
- Energy saving, long lifespan
- Light is soft and uniform, safe to eyes
- Instant start, NO flickering, NO humming
- Green and eco-friendly without mercury.

Application :

- Gas station

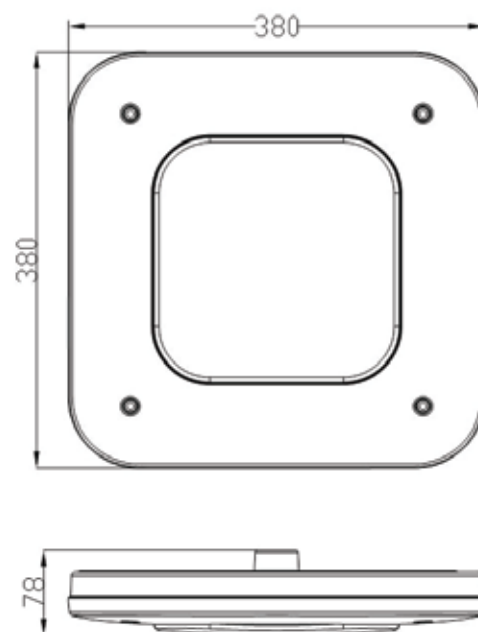



LED Canopy Light

P/N : GSL-71502-XX

Advantage :

- UL cUL DLC certificate
- High CRI
- Mean Well IP65 driver, Input voltage 100-277Vac
- No UV or IR in the beam
- Easy to install and operate
- Energy saving, Long lifespan
- Light is soft and uniform, Safe to eyes
- Instant start, NO flickering, NO humming
- Green and eco-friendly without mercury.

Application :

- Gas station
- Service station, Toll station.

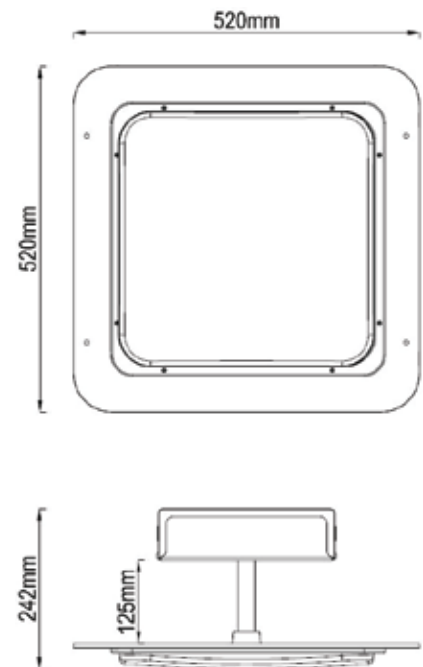

Bay Lights

100W 12000 lumens 5000K bay light UL DLC

Lumens: 12000	Fixture Color: Black
Watts: 100	Fixture Material: Aluminum Alloy
Light Color (Kelvin): 5000	Lifetime (Hours): 50,000
Voltage: 100-277V AC	Master Carton Quantity: 1
Base Type:	Master Carton Size:
Size in Inches: 12.6 x 7.3	Master Carton Weight:
Size in mm: 320 x 185	Warranty (Years): 5
CRI (Ra): >80	Luminous efficacy: 120 lm/W
LED Type: Philips 3030	Working Temperature: -20°F to
Beam Angle: 60°	+122°F (-30°C to +50°C)
(or 90° or 120° to order)	Certification: UL, DLC
IP rating: 65	Net Weight: 10.78 lbs (4.9 kg)

Power Factor (PF): >0.9

Notes: Fixed installation. No fan.

Available with a different color ring (Green, Red, Blue or Black).

Item Code: **BYL-71002-05**



Compares to a 300W MH/HPS/HID

150W 19000 lumens 5000K bay light UL DLC

Lumens: 19000	Fixture Color: Black
Watts: 150	Fixture Material: Aluminum Alloy
Light Color (Kelvin): 5000	Lifetime (Hours): 50,000
Voltage: 100-277V AC	Master Carton Quantity: 1
Base Type:	Master Carton Size:
Size in Inches: 12.6 x 7.3	Master Carton Weight:
Size in mm: 320 x 185	Warranty (Years): 5
CRI (Ra): >80	Luminous efficacy: 127 lm/W
LED Type: Philips Lumileds 3030	Working Temperature: -20°F to
Beam Angle: 60°	+122°F (-30°C to +50°C)
(or 90° or 120° to order)	Certification: UL DLC
IP rating: 65	Net Weight: 11.66 lbs (5.3 kg)

Power Factor (PF): >0.9

Notes: Fixed installation. No fan.

Available with a different color ring (Green, Red, Blue or Black).

Item Code: **BYL-71502-05**



Compares to a 450W MH/HPS/HID

EXXON Lighting Corporation



Bay Lights

200W 25000lm 5000K 100-277V Bay Light	
Lumens: 25000	Master Carton Size: 17.7" x 17.7" x 8.26" (450mm x 450mm x 210 mm)
Watts: 200	
Light Color (Kelvin): 5000	Master Carton Wgt: 19.4 lbs (8.8 kg)
Voltage: 100-277V AC	LED Type: Philips 3030
Base Type: N/A	Power Factor (PF): >0.9
Size in Inches: 15.7 x 7.9	Fixture Material: ALU Alloy plus
Size in mm: 400 x 200	Tempered Glass Cover
CRI (Ra): >80	Warranty (Years): 5
Beam Angle: 60° (or 90° or 120° to order)	Luminous efficacy: 125 lm/W
	Working Temperature: -40 to +122 (-40 to +50)
IP rating: 65	Certification: UL, DLC
Fixture Color: Black or White	
Lifetime (Hours): 50,000	Net Weight: 16.72 lbs (7.58 kg)
Master Carton Quantity: 1	Copmares to: 600WMH, 600WHPS, 600WHID

Item Code: **BYL-72002-05**



Compares to a 300W MH/HPS/HID

240W 31000lm 5000K 100-277V Bay Light	
Lumens: 31000	Carton Size:
Watts: 240	Carton Weight:
Light Color (Kelvin): 5000	LED Type: Philips 3030
Voltage: 100-277V AC	Power Factor (PF): >0.9
Base Type: N/A	Fixture Material: ALU Alloy plus
Size in Inches: 15.7 x 7.9	Tempered Glass Cover
Size in mm: 400 x 200	Warranty (Years): 5
CRI (Ra): >80	Luminous efficacy: 129 lm/W
Beam Angle: 60° (or 90° or 120° to order)	Working Temperature: -40 to +122 (-40 to +50C)
IP rating: 65	Certification: UL, DLC
Fixture Color: Black or White	Net Weight: 16.72 lbs (7.58 kg)
Lifetime (Hours): 50,000	Compares to: 700WMH, 700WHPS, 700WHID
Master Carton Quantity: 1	Notes:

Item Code: **BYL-72402-05**



Compares to a 450W MH/HPS/HID

Bay Lights/Flood Lights/Sports Lights

80W 8000 LUMENS 6000K Bay LIGHT UL

Lumens: 8000	Fixture Color: Black
Watts: 80	(White or Silver available)
Light Color (Kelvin): 6000	Fixture Material: Anodized Aluminum
Voltage: 90-305V AC	Lifetime (Hours): 50,000
(or 12V/24V DC)	Carton Quantity: 1
Base Type: 3 Wire	Carton Size: 14.96" x 11.81" x 8.85"
Size in Inches: 11.93 x 9.13 x 7.2	(380mm x 300mm x 225 mm)
Size in mm: 303 x 232 x 183	Carton Weight: 17.86 lbs (8.1 kg)
CRI (Ra): >70	Warranty (Years): 5
LED Type: Philips LUXEON T	Luminous efficacy: 100 lm/W
Beam Angle: 100°	Working Temperature:
IP rating: 65	-40°F to +122°F (-40°C to +50°C)
Power Factor (PF): >0.95	Certification: UL, CE, RoHS, TUV, SAA
	Net Weight: 11.35 lbs (5.15 kg)
	Notes: 3000K/4000K available

Item Code: BYL-48072



Compares to a 250W MH/HPS/HID, 125W CFL

120W 12000 LUMENS 6000K Bay Light UL

Lumens: 12000	Fixture Color: Black
Watts: 120	(White or Silver available)
Light Color (Kelvin): 6000	Fixture Material: Anodized Aluminum
Voltage: 90-305V AC	Lifetime (Hours): 50,000
(or 12V/24V DC)	Carton Quantity: 1
Base Type: 3 Wire	Carton Size: 14.76" x 18.5" x 8.85"
Size in Inches: 11.93 x 12.24 x 7.71	(375mm x 470mm x 225 mm)
Size in mm: 303 x 311 x 196	Carton Weight: 20.5 lbs (9.3 kg)
CRI (Ra): >70	Warranty (Years): 5
LED Type: Philips LUXEON T	Luminous efficacy: 100 lm/W
Beam Angle: 100°	Working Temperature: -40°F to
IP rating: 65	+122°F (-40°C to +50°C)
Power Factor (PF): >0.95	Certification: UL, CE, RoHS, TUV, SAA
	Net Weight: 13.56 lbs (6.15 kg)
	Notes: 3000K/4000K available

Item Code: BYL-41277



Compares to a 400W MH/HPS/HID

EXXON Lighting Corporation



Bay Lights/Flood Lights/Sports Lights

160W 16000 LUMENS 6000K Bay Light UL

Lumens: 16000	Fixture Color: Black
Watts: 160	(White or Silver available)
Light Color (Kelvin): 6000	Fixture Material: Anodized Aluminum
Voltage: 90-305V AC	Lifetime (Hours): 50,000
(or 12V/24V DC)	Carton Quantity: 1
Base Type: 3 Wire	Carton Size: 18" x 15" x 9.5"
Size in Inches: 15.43 x 11.93	(457mm x 381mm x 241 mm)
x 7.72	Carton Weight: 19.38 lbs (8.79 kg)
Size in mm: 392 x 303 x 196	Warranty (Years): 5
CRI (Ra): >70	Luminous efficacy: 100 lm/W
LED Type: Philips LUXEON T	Working Temperature: -40°F to
Beam Angle: 100°	+122°F (-40°C to +50°C)
IP rating: 65	Certification: UL, CE, RoHS, TUV, SAA
Power Factor (PF): >0.95	Net Weight: 16.53 lbs (7.15 kg)
	Notes: 3000K/4000K available

Item Code: BYL-41691



Compares to a 450W MH/HPS/HID

200W 20000 LUMENS 6000K Bay LIGHT UL

Lumens: 20000	Fixture Color: Black
Watts: 200	(White or Silver available)
Light Color (Kelvin): 6000	Fixture Material: Anodized Aluminum
Voltage: 90-305V AC	Lifetime (Hours): 50,000
(or 12V/24V DC)	Carton Quantity: 1
Base Type: 3 Wire	Carton Size: 21.33" x 14.76" x 10.03"
Size in Inches: 18.62 x 11.96 x 7.72	(542 x 375 x 255 mm)
Size in mm: 473 x 304 x 196	Carton Weight: 26.01 lbs (11.8 kg)
CRI (Ra): >70	Warranty (Years): 5
LED Type: Philips LUXEON T	Luminous efficacy: 100 lm/W
Beam Angle: 100°	Working Temperature: -40°F to
IP rating: 65	+122°F (-40°C to +50°C)
Power Factor (PF): >0.95	Certification: UL, CE, RoHS, TUV, SAA
	Net Weight: 18.74 lbs (8.5 kg)
	Notes: 3000K/4000K available

Item Code: BYL-42087



Compares to a 500W MH/HPS/HID

Bay Lights/Flood Lights/Sports Lights

240W 24000 LUMENS 5700K Bay Light UL

Lumens: 24000	Fixture Color: Black
Watts: 240	(White or Silver available)
Light Color (Kelvin): 5700	Fixture Material: Anodized Aluminum
Voltage: 90-305V AC (or 12V/24V DC)	Lifetime (Hours): 50,000
Base Type: 3 Wire	Carton Quantity: 1
Size in Inches: 21.81 x 11.96 x 7.72	Carton Size: 14.76" x 24.6" x 8.85" (375 x 625 x 225 mm)
Size in mm: 554 x 304 x 196	Carton Weight: 29.76 lbs (13.5 kg)
CRI (Ra): >70	Warranty (Years): 5
LED Type: Philips LUXEON T	Luminous efficacy: 100 lm/W
Beam Angle: 100°	Working Temperature: -40°F to +122°F (-40°C to +50°C)
IP rating: 65	
Power Factor (PF): >0.95	Certification: UL, CE, RoHS, TUV, SAA
	Net Weight: 20.39 lbs (9.25 kg)
	Notes: 3000K/4000K available

Item Code: BYL-42465



Compares to a 600W MH/HPS/HID

280W 28000 LUMENS 5700K Bay Light UL

Lumens: 28000	Fixture Color: Black
Watts: 280	(White or Silver available)
Light Color (Kelvin): 5700	Fixture Material: Anodized Aluminum
Voltage: 90-305V AC (or 12V/24V DC)	Lifetime (Hours): 50,000
Base Type: 3 Wire	Master Carton Quantity: 1
Size in Inches: 25 x 11.92 x 7.67	Master Carton Size: 14.76" x 27.75" x 8.85" (375 x 705 x 225 mm)
Size in mm: 635 x 303 x 195	Master Carton Wgt: 31.42 lbs (14.25 kg)
CRI (Ra): >70	Warranty (Years): 5
LED Type: Philips LUXEON T	Luminous efficacy: 100 lm/W
Beam Angle: 100°	Working Temperature: -40°F to +122°F (-40°C to +50°C)
IP rating: 65	
Power Factor (PF): >0.95	Certification: UL, CE, RoHS, TUV, SAA
	Net Weight: 23.15 lbs (10.5 kg)
	Notes: 3000K/4000K available

Item Code: BYL-42834



Compares to a 700W MH/HPS/HID

EXXON Lighting Corporation



Linear High Bays

Beam Angle is 90° as standard.
Beam angle of 100° x 65° or 135° x 70° is optional at time of order.

50W 5800 LUMENS 5000K LINEAR Bay Light UL DLC	
Lumens: 5800	Fixture Color: Black
Watts: 50	Fixture Material: Aluminum + PC
Light Color (Kelvin): 5000	Lifetime (Hours): 50,000
Voltage: 120-277V AC	Master Carton Quantity: 1
Base Type: N/A	Master Carton Size: 19.5" x 9" x 6.5"
Size in Inches: 13 x 5.6 x 4.4	(495mm x 230mm x 165mm)
Size in mm: 329 x 142.2 x 112.5	Master Carton Weight: 8.4 lbs (3.8 kg)
CRI (Ra): >70	Warranty (Years): 5
LED Type: Philips Lumileds 3030 2D x 56	Luminous efficacy: 116 lm/W
Beam Angle: 90°	Working Temperature: -4°F to +113°F (-20°C to +45°C)
IP rating: 66	Certification: UL, cUL, DLC
Power Factor (PF): >0.9	Net Weight: 6.6 lbs (3 kg)
	Notes: Can be mounted with chains or brackets

Item Code: **BYA-70502-05**



100W 13600 LUMENS 5000K LINEAR Bay Light UL DLC	
Lumens: 13600	Fixture Color: Black
Watts: 100	Fixture Material: Aluminum + PC
Light Color (Kelvin): 5000	Lifetime (Hours): 50,000
Voltage: 120-277V AC	Master Carton Quantity: 1
Base Type: N/A	Master Carton Size: 31.3" x 9" x 6.5"
Size in Inches: 24.6 x 5.6 x 4.4	(795mm x 230mm x 165mm)
Size in mm: 624 x 142.2 x 112.5	Master Carton Weight: 12.12.lbs (5.5 kg)
CRI (Ra): >70	Warranty (Years): 5
LED Type: Philips Lumileds 3030 2D x 112	Luminous efficacy: 136 lm/W
Beam Angle: 90°	Working Temperature: -4°F to +113°F (-20°C to +45°C)
IP rating: 66	Certification: UL, cUL, DLC
Power Factor (PF): >0.9	Net Weight: 9.9 lbs (4.5 kg)
	Notes: Can be mounted with chains or brackets

Item Code: **BYA-71002-05**



Linear High Bays

Beam Angle is 90° as standard.
Beam angle of 100° x 65° or 135° x 70° is optional at time of order.

150W 20400 LUMENS 5000K LINEAR Bay Light UL DLC

Lumens: 20400	Fixture Color: Black
Watts: 150	Fixture Material: Aluminum + PC
Light Color (Kelvin): 5000	Lifetime (Hours): 50,000
Voltage: 120-277V AC	Master Carton Quantity: 1
Base Type: N/A	Master Carton Size: 42.9" x 9" x 6.5"
Size in Inches: 32.6 x 5.6 x 4.4	(1090mm x 230mm x 165mm)
Size in mm: 919 x 142.2 x 112.5	Master Carton Weight: 17 lbs (7.7 kg)
CRI (Ra): >70	Warranty (Years): 5
LED Type: Philips Lumileds	Luminous efficacy: 136 lm/W
3030 2D x 168	Working Temperature: -4°F to +113°F (-20°C to +45°C)
Beam Angle: 90°	
IP rating: 66	Certification: UL, cUL, DLC
Power Factor (PF): >0.9	Net Weight: 13.4 lbs (6.1 kg)
	Notes: Can be mounted with chains or brackets

Item Code: **BYA-71502-05**



200W 28000 LUMENS 5000K LINEAR Bay Light UL DLC

Lumens: 28000	Fixture Color: Black
Watts: 200	Fixture Material: Aluminum + PC
Light Color (Kelvin): 5000	Lifetime (Hours): 50,000
Voltage: 120-277V AC	Master Carton Quantity: 1
Base Type: N/A	Master Carton Size: 54.5" x 9" x 6.5"
Size in Inches: 47.8 x 5.6 x 4.4	(1385mm x 230mm x 165mm)
Size in mm: 1214 x 142.2 x 112.5	Master Carton Weight: 20.3 lbs (9.2 kg)
CRI (Ra): >70	Warranty (Years): 5
LED Type: Philips Lumileds	Luminous efficacy: 140 lm/W
3030 2D x 224	Working Temperature: -4°F to +113°F (-20°C to +45°C)
Beam Angle: 90°	
IP rating: 66	Certification: UL, cUL, DLC
Power Factor (PF): >0.9	Net Weight: 16.75 lbs (7.6 kg)
	Notes: Can be mounted with chains or brackets

Item Code: **BYA-72002-05**



EXXON Lighting Corporation



Linear High Bays

Beam Angle is 90° as standard.
Beam angle of 100° x 65° or 135° x 70° is optional at time of order.

240W 32900 LUMENS 5000K LINEAR Bay Light UL DLC	
Lumens: 32900	Fixture Color: Black
Watts: 240	Fixture Material: Aluminum + PC
Light Color (Kelvin): 5000	Lifetime (Hours): 50,000
Voltage: 120-277V AC	Master Carton Quantity: 1
Base Type: N/A	Master Carton Size: 66.1" x 9" x 6.5"
Size in Inches: 59.4 x 5.6 x 4.4	(1680mm x 230mm x 165mm)
Size in mm: 1509 x 142.2 x 112.5	Master Carton Weight: 23.4 lbs (10.6 kg)
CRI (Ra): >70	Warranty (Years): 5
LED Type: Philips Lumileds 3030 2D x 280	Luminous efficacy: 137 lm/W
Beam Angle: 90°	Working Temperature: -4°F to +113°F (-20°C to +45°C)
IP rating: 66	Certification: UL, cUL, DLC
Power Factor (PF): >0.9	Net Weight: 19.84 lbs (9 kg)
	Notes: Can be mounted with chains or brackets

Item Code: BYA-72402-05

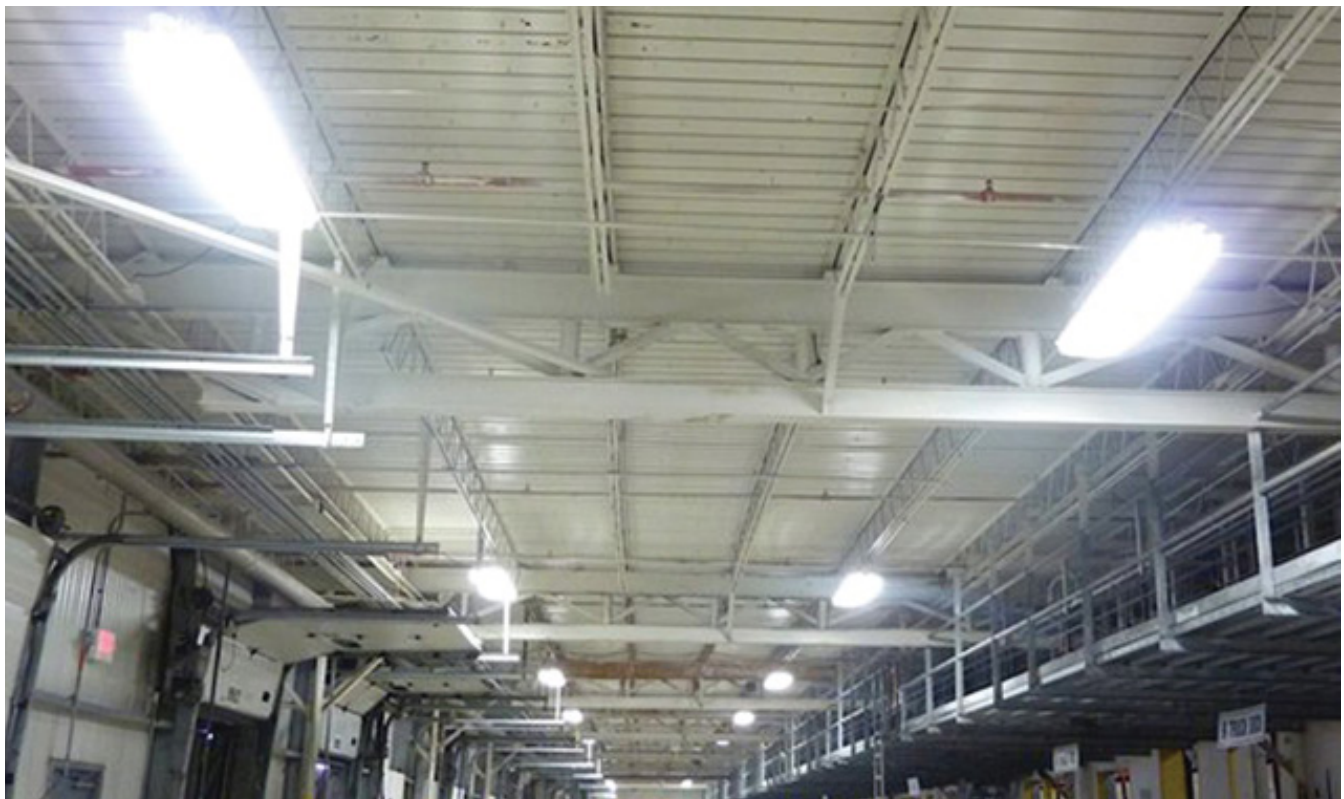

Wall Packs

25W 3300 LUMENS 5000K WALL PACK/WASHER UL DLC

Lumens: 3300	Fixture Color: Black
Watts: 25	Fixture Material: Aluminum + PC
Light Color (Kelvin): 5000	Lifetime (Hours): 50,000
Voltage: 120-277V AC	Master Carton Quantity: 8
Base Type: N/A	M Carton Size: 19.5" x 11.6" x 13.2"
Size in Inches: 9.1 x 5.2 x 5.4	(495mm x 295mm x 335 mm)
Size in mm: 232 x 132 x 137	Master Carton Weight: 37.5 lbs (17 kg)
CRI (Ra): >70	Warranty (Years): 5
LED Type: CREE MHB-B x 10 pieces	Luminous efficacy: 132 lm/W
Beam Angle: 60°	Working Temperature: -4°F to +113°F (-20°C to +45°C)
IP rating: 65	
Power Factor (PF): >0.9	Certification: UL, cUL, DLC
	Net Weight: 3.96 lbs (1.8 kg)
	Notes:

Item Code: WPS-70252-05



Compares to a 70W MH/HPS/HID

40W 5100 LUMENS 5000K WALL PACK/WASHER UL DLC

Lumens: 5100	Fixture Color: Black
Watts: 40	Fixture Material: Aluminum + PC
Light Color (Kelvin): 5000	Lifetime (Hours): 50,000
Voltage: 120-277V AC	Master Carton Quantity: 8
Base Type: N/A	M Carton Size: 19.5" x 11.6" x 13.2"
Size in Inches: 9.1 x 5.2 x 5.4	(495mm x 295mm x 335 mm)
Size in mm: 232 x 132 x 137	Master Carton Weight: 37.5 lbs (17 kg)
CRI (Ra): >70	Warranty (Years): 5
LED Type: CREE MHB-B x 15 pcs.	Luminous efficacy: 128 lm/W
Beam Angle: 60°	Working Temperature: -4°F to +113°F (-20°C to +45°C)
IP rating: 65	
Power Factor (PF): >0.9	Certification: UL, cUL, DLC
	Net Weight: 4.18 lbs (1.9 kg)
	Notes:

Item Code: WPS-70402-05



Compares to a 100W MH/HPS/HID

EXXON Lighting Corporation



Wall Packs

60W 7700 LUMENS 5000K WALL PACK/WASHER UL DLC	
Lumens: 7700	Fixture Color: Black
Watts: 60	Fixture Material: Aluminum + PC
Light Color (Kelvin): 5000	Lifetime (Hours): 50,000
Voltage: 120-277V AC	Master Carton Quantity: 4
Base Type: N/A	M Carton Size: 19.5" x 11.6" x 13.2"
Size in Inches: 9.1 x 5.2 x 8.8	(495mm x 295mm x 335mm)
Size in mm: 232 x 132 x 225	Master Carton Weight: 30.4 lbs (13.8 kg)
CRI (Ra): >70	Warranty (Years): 5
LED Type: CREE MHB-B x 20 pcs	Luminous efficacy: 128 lm/W
Beam Angle: 60°	Working Temperature: -4° F to +113° F (-20° C to +45° C)
IP rating: 65	
Power Factor (PF): >0.9	Certification: UL, cUL, DLC
	Net Weight: 6.6 lbs (3 kg)
	Notes:

Item Code: WPS-70602-05



Compares to a 150W MH/HPS/HID

80W 12000 LUMENS 5000K WALL PACK/WASHER UL DLC	
Lumens: 12000	Fixture Color: Black
Watts: 80	Fixture Material: Aluminum + PC
Light Color (Kelvin): 5000	Lifetime (Hours): 50,000
Voltage: 120-277V AC	Master Carton Quantity: 4
Base Type: N/A	M Carton Size: 19.5" x 11.6" x 10.4"
Size in Inches: 9.1 x 5.2 x 8.8	(495mm x 295mm x 265mm)
Size in mm: 232 x 132 x 225	Master Carton Wgt: 30.4 lbs (13.8 kg)
CRI (Ra): >70	Warranty (Years): 5
LED Type: CREE MHB-B x 30 pcs.	Luminous efficacy: 128 lm/W
Beam Angle: 60°	Working Temperature: -4° F to +113° F (-20° C to +45° C)
IP rating: 65	
Power Factor (PF): >0.9	Certification: UL, cUL, DLC
	Net Weight: 6.6 lbs (3 kg)
	Notes:

Item Code: WPS-70802-05



Compares to a 400W MH/HPS/HID

Wall Packs

60W 6900 LUMENS 5000K WALL PACK/WASHER UL DLC

Lumens: 6900	Fixture Color: Brown
Watts: 60	Fixture Material: Aluminum + PC
Light Color (Kelvin): 5000	Lifetime (Hours): 50,000
Voltage: 120-277V AC	Master Carton Quantity: 1
Base Type: N/A	M Carton Size: 15.74" x 11.8" x 9.45"
Size in Inches: 14.2 x 9.25 x 7.63	(400mm x 300mm x 240mm)
Size in mm: 360 x 235 x 194	Master Carton Weight: 10.14 lbs (4.6 kg)
CRI (Ra): >70	Warranty (Years): 5
LED Type: Epistar 2835 x 210 pcs.	Luminous efficacy: 115 lm/W
Beam Angle: 110°	Working Temperature: -4°F to +113°F (-20°C to +45°C)
IP rating: 65	
Power Factor (PF): >0.9	Certification: UL, cUL, DLC
	Net Weight: 7.48 lbs (3.4 kg)
	Notes:

Item Code: WPL-70602-05



Compares to a 175W MH/HPS/HID

80W 9200 LUMENS 5000K WALL PACK/WASHER UL DLC

Lumens: 9200	Fixture Color: Brown
Watts: 80	Fixture Material: Aluminum + PC
Light Color (Kelvin): 5000	Lifetime (Hours): 50,000
Voltage: 120-277V AC	Master Carton Quantity: 1
Base Type: N/A	M Carton Size: 15.74" x 11.8" x 9.45"
Size in Inches: 14.2 x 9.25 x 7.63	(400mm x 300mm x 240mm)
Size in mm: 360 x 235 x 194	Master Carton Wgt: 10.14 lbs (4.6 kg)
CRI (Ra): >70	Warranty (Years): 5
LED Type: Epistar 2835 x 270 pcs	Luminous efficacy: 115 lm/W
Beam Angle: 110°	Working Temperature: -4°F to +113°F (-20°C to +45°C)
IP rating: 65	
Power Factor (PF): >0.9	Certification: UL, cUL, DLC
	Net Weight: 7.71 lbs (3.5 kg)
	Notes:

Item Code: WPL-70802-05



Compares to a 250W MH/HPS/HID

EXXON Lighting Corporation



Wall Packs

100W 11500 LUMENS 5000K WALL PACK/WASHER UL DLC	
Lumens: 11500	Fixture Color: Brown
Watts: 100	Fixture Material: Aluminum + PC
Light Color (Kelvin): 5000	Lifetime (Hours): 50,000
Voltage: 120-277V AC	Master Carton Quantity: 1
Base Type: N/A	M Carton Size: 19.3" x 12.6" x 11.4"
Size in Inches: 18.1 x 9.8 x 8.8	(490mm x 320mm x 290mm)
Size in mm: 460 x 248 x 223	Master Carton Wgt: 14.33 lbs (6.5 kg)
CRI (Ra): >80	Warranty (Years): 5
LED Type: Epistar 2835 x 360 pcs	Luminous efficacy: 115 lm/W
Beam Angle: 110°	Working Temperature: -4°F to +113°F (-20°C to +45°C)
IP rating: 65	
Power Factor (PF): >0.9	Certification: UL, cUL, DLC
	Net Weight: 12.12 lbs (5.5 kg)
	Notes:

Item Code: WPS-70602-05



Compares to a 150W MH/HPS/HID

120W 11500 LUMENS 5000K WALL PACK/WASHER UL DLC	
Lumens: 11500	Fixture Color: Brown
Watts: 120	Fixture Material: Aluminum + PC
Light Color (Kelvin): 5000	Lifetime (Hours): 50,000
Voltage: 120-277V AC	Master Carton Quantity: 1
Base Type: N/A	M Carton Size: 19.3" x 12.6" x 11.4"
Size in Inches: 18.1 x 9.8 x 8.8	(490mm x 320mm x 290mm)
Size in mm: 460 x 248 x 223	Master Carton Wgt: 14.33 lbs (6.5 kg)
CRI (Ra): >80	Warranty (Years): 5
LED Type: Epistar 2835 x 420 pcs	Luminous efficacy: 115 lm/W
Beam Angle: 110°	Working Temperature: -4°F to +113°F (-20°C to +45°C)
IP rating: 65	
Power Factor (PF): >0.9	Certification: UL, cUL, DLC
	Net Weight: 12.12 lbs (5.5 kg)
	Notes:

Item Code: WPL-71202-05



Compares to a 400W MH/HPS/HID

Flood Lights

400W 44000 LUMENS 6000K FloodLight ETL/DLC

Lumens: 44000	Master Carton Quantity:
Watts: 400 (+ 40 for driver)	Master Carton Size: 26.2" x 28.6" x 9.1"
Light Color (Kelvin): 6000	(665mm x 725mm x 230mm)
Voltage: 90-305V AC (347-480V AC avail.)	Carton Weight: 48.5 lbs (22 kg)
Base Type: 3 Wire	Lifetime (Hours): >50,000
Size in Inches: 23.85 x 22.48 x 4.6	Fixture Color: Black
Size in mm: 606 x 571 x 117	Fixture Material: Aluminum
CRI (Ra): 70	Warranty (Years): 5
Beam Angle: 15° 30° 40° 60°	Luminous efficacy: 110 lm/W
60° x 135° and 85° x 135°	Working Temperature: -49°F to +45°F (-40°C to +44°C)
IP rating: 65	Certification: ETL, CE, RoHS, DLC
Power Factor (PF): 0.95	Net Weight: 44.09 lbs (20 kg)
LED Type: Cree XP-G2/Philips Rebel ES	Notes: Meanwell Driver (HLG series). 3000K-7000K available

Item Code: FLL-44013



Compares to a 1000W MH/HPS/HID

500W 55000 LUMENS 6000K FloodLight

Lumens: 55000	Master Carton Quantity:
Watts: 500 (+ 50 for driver)	Master Carton Size: 36.7" x 28.8" x 9.1"
Light Color (Kelvin): 6000	(930mm x 730mm x 230mm)
Voltage: 90-305V AC (347-480V AC avail.)	Carton Weight: 68.3 lbs (31 kg)
Base Type: 3 Wire	Lifetime (Hours): >50,000
Size in Inches: 31.9 x 23.8 x 4.6	Fixture Color: Black
Size in mm: 811 x 606 x 117	Fixture Material: Aluminum
CRI (Ra): 70	Warranty (Years): 5
Beam Angle: 15° 30° 40° 60°	Luminous efficacy: 110 lm/W
60° x 135° and 85° x 135°	Working Temperature: -49°F to +45°F (-40°C to +44°C)
IP rating: 65	Certification: CE, RoHS, LM79
Power Factor (PF): 0.95	Net Weight: 62.6 lbs (28.4 kg)
LED Type: Cree XP-G2/Philips Rebel ES	Notes: Meanwell Driver (HLG series). 3000K-7000K available

Item Code: FLL-45039



Compares to a 1200W MH/HPS/HID

EXXON Lighting Corporation

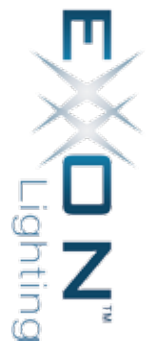

Flood Lights

600W 64000 LUMENS 6000K FloodLight ETL/DLC	
Lumens: 64000	Master Carton Quantity:
Watts: 580 (+ 60 for driver)	Master Carton Size: 36.7" x 28.8" x 9.1"
Light Color (Kelvin): 6000	(930 x 730 x 230mm)
Voltage: 90-305V AC (347-480V AC avail.)	Carton Weight: 63.9 lbs (29 kg)
Base Type: 3 Wire	Lifetime (Hours): >50,000
Size in Inches: 31.9 x 23.8 x 4.6	Fixture Color: Black
Size in mm: 811 x 606 x 117	Fixture Material: Aluminum
CRI (Ra): 70	Warranty (Years): 5
Beam Angle: 15° 30° 40° 60°	Luminous efficacy: 107 lm/W
60° x 135° and 85° x 135°	Working Temperature: -49°F to +45°F (-40°C to +44°C)
IP rating: 65	Certification: ETL, CE, RoHS, DLC
Power Factor (PF): 0.95	Net Weight: 62.6 lbs (28.4 kg)
LED Type: Cree XP-G2/Philips Rebel ES	Notes: Meanwell Driver (HLG series). 3000K-7000K available

Item Code: FLL-46074



Compares to a 1500W MH/HPS/Hid



Corn Lights

Available in a variety of wattages, lumens, colors (Kelvin), and base sizes

9W 990 lumens 5000K Corn Light E26 Medium Base UL

Lumens: 990	Fixture Color: White
Watts: 9	Master Carton Quantity: 12
Light Color (Kelvin): 5000	Master Carton Size: 12.6" x 9.8" x 9.8"
Voltage: 100-277V AC	(320mm x 250mm x 250mm)
Base Type: E26 Medium	Master Carton Wgt: 24.25 lbs (11 kg)
Size in Inches: 1.77 x 5.7	Lifetime (Hours): >50,000
Size in mm: 45 x 145	Fixture Material: Aluminum/PC
CRI (Ra): >70	Warranty (Years): 5
Beam Angle: 360°	Luminous efficacy: 110 lm/W
IP rating: 64	Working Temperature: -4°F to 113°F (-20°C to +45°C)
LED Type: Epistar	
Power Factor (PF): >0.9	Certification: UL, cUL
	Net Weight: 0.3 lbs (0.14 kg)
Notes: Suitable for use in enclosed luminaires, min. lamp compartment dimensions: 12.2" x 7.5" x 7.5" (310mm x 190mm x 190mm).	

Item Code: CNL-60965



Compares to an 80W incandescent, 25W CFL

12W 1320 lumens 5000K Corn Light E26 Medium Base UL

Lumens: 1320	Fixture Color: White
Watts: 12	Master Carton Quantity: 50
Light Color (Kelvin): 5000	Master Carton Size: 13.8" x 9.8" x 9.8"
Voltage: 100-277 AC	(350mm x 250mm x 250mm)
Base Type: E26 Medium	Master Carton Wgt: 20.8 lbs (9.43 kg)
Size in Inches: 1.77 x 6.5	Lifetime (Hours): >50,000
Size in mm: 45 x 165	Fixture Material: Aluminum/PC
CRI (Ra): >70	Warranty (Years): 5
Beam Angle: 360°	Luminous efficacy: 110 lm/W
IP rating: 64	Working Temperature: -4°F to 113°F (-20°C to +45°C)
LED Type: Epistar 2835 x 98	
Power Factor (PF): >0.9	Certification: UL, cUL
	Net Weight: 0.35 lbs (0.16 kg)
Notes: Suitable for use in enclosed luminaires, min. lamp compartment dimensions: 12.2" x 7.5" x 7.5" (310mm x 190mm x 190mm).	

Item Code: CNL-61255



Compares to 100W incandescent, 30W CFL

EXXON Lighting Corporation



Corn Lights

12W 1900K Corn Light E26 Medium Base Turtle Friendly UL	
Lumens:	Fixture Color: White/Silver
Watts: 12	Master Carton Quantity: 12
Light Color (Kelvin): 1900 (590 nm)	Master Carton Size: 18.12" x 14.17" x 9.45" (460 x 360 x 240mm)
Voltage: 100-277V AC	
Base Type: E26 Medium	Master Carton Wgt: 11.88 lbs (5.4 kg)
Size in Inches: 6.5 x 2.76	Lifetime (Hours): >50,000
Size in mm: 165 x 70	Fixture Material: Aluminum/PC
CRI (Ra):	Warranty (Years): 5
Beam Angle: 360°	Luminous efficacy:
IP rating: 64	Working Temperature: -20° F to 140° F (-29° C to +60° C)
LED Type: Epistar 3528 x 136	
Power Factor (PF): >0.9	Certification: UL, CE, RoHS
	Net Weight: 0.7 lbs (320 g)
	Notes: Turtle Friendly Lamp.

Item Code: CNL-51246



Compares to 50W MH/HPS/HID

15W 1650lm 5000K Corn Light E26 Medium Base UL	
Lumens: 1650	Fixture Color: White
Watts: 15	Master Carton Quantity: 24
Light Color (Kelvin): 5000	Master Carton Size: 16.9" x 13" x 16.5" (430mm x 330mm x 420mm)
Voltage: 100-277V AC	
Base Type: E26 Medium	Master Carton Wgt: 23.8 lbs (10.8 kg)
Size in Inches: 2.75 x 9	Lifetime (Hours): >50,000
Size in mm: 70 x 160	Fixture Material: Clear PC
CRI (Ra): >70	Warranty (Years): 5
Beam Angle: 360°	Luminous efficacy: 110 lm/W
IP rating: 64	Working Temperature: -4° F to 113° F (-20° C to +45° C)
LED Type: Epistar SMD2835 x 120 pieces	Certification: cULus, CE, RoHS
Power Factor (PF): >0.9	Net Weight: 0.7 lbs (300 g)
	Notes: Suitable for use in enclosed luminaires, min. lamp compartment dimensions: 12.2" x 7.5" x 7.5" (310mm x 190mm x 190mm).

Item Code: CNL-61592



Compares to a 120W incandescent, 40W CFL



Corn Lights

20W 2300 lumens 5500K LED Corn Light E26 MEDIUM Base

Lumens: 2300	Fixture Color: White
Watts: 20	Fixture Material: Polycarbonate
Light Color (Kelvin): 5500	Lifetime (Hours): >50,000
Voltage: 100-300V AC	Master Carton Quantity: 24
Base Type: E26 Medium	M Carton Size: 16.9" x 13" x 15.7"
Size in Inches: 2.91 x 5.9	(430mm x 330mm x 398mm)
Size in mm: 73 x 150	Master Carton Wgt: 15.4 lbs (7.0 kg)
CRI (Ra): >70	Warranty (Years): 5
LED Type: 2835 x 108	Luminous efficacy: 115 lm/W
Beam Angle: 360°	Working Temperature: -4°F to +113°F (-20°C to +45°C)
IP rating: 40	
Power Factor (PF): >0.90	Certification: UL, CE, RoHS
	Net Weight: 0.33 lbs (150 g)
	Notes: Suitable for use in enclosed luminaires, min. lamp compartment dims: 11.8" x 7.9" x 7.9" (300mm x 200mm x 200mm).

Item Code: CNL-22872



Compares to a 60W MH/HPS/HID, 60W CFL, 200W incandescent

20W 2300 lumens 5500K LED Corn Light E26 Base UL

Lumens: 2300	Fixture Color: White
Watts: 20	Fixture Material: Polycarbonate
Light Color (Kelvin): 5500	Lifetime (Hours): >50,000
Voltage: 100-277V AC	Master Carton Quantity: 24
Base Type: E26 Medium	M Carton Size: 16.3" x 12.4" x 18.1"
Size in Inches: 2.75 x 7.09	(415mm x 315mm x 460mm)
Size in mm: 70 x 180	Master Carton Wgt: 22.9 lbs (10.4 kg)
CRI (Ra): >70	Warranty (Years): 5
LED Type: Epistar 2835 x 140	Luminous efficacy: 115 lm/W
Beam Angle: 360°	Working Temperature: -4°F to +113°F (-20°C to +45°C)
IP rating: 64	
Power Factor (PF): >0.95	Certification: UL, CE, RoHS
	Net Weight: 0.66 lbs (0.3 kg)
	Notes: Suitable for use in enclosed luminaires, min. lamp compartment dimensions: 12.6" x 7.5" x 7.5" (320mm x 190mm x 190mm).

Item Code: CNL-62055



Compares to a 60W MH/HPS/HID, 200W Incandescent, 60W CFL

EXXON Lighting Corporation



Corn Lights

30W 3300 LUMENS 3000/6000K Corn Light E26 Base UL	
Lumens: 3300	Fixture Color: White
Watts: 30	Fixture Material: Aluminum/PC
Light Color (Kelvin): 3000/4500	Lifetime (Hours): >50,000
/6000	Master Carton Quantity: 12
Voltage: 100-277V AC	Master Carton Size: 20" x 15" x 11"
Base Type: E26 Medium	(508mm x 381mm x 279mm)
(also available in E39 Mogul)	Master Carton Wgt: 20.28 lbs (9.2 kg)
Size in Inches: 3.66 x 8.26	Warranty (Years): 5
Size in mm: 93 x 210	Luminous efficacy: 110 lm/W
CRI (Ra): >70	Working Temperature: -4°F to
LED Type: 2835 x 228 pieces	+113°F (-20°C to +45°C)
Beam Angle: 360°	Certification: UL, CE, RoHS
IP rating: 64	Net Weight: 1.1 lbs (500 g)
Power Factor (PF): >90%	Notes: Suitable for use in enclosed luminaires, min. lamp compartment dimensions: 13.4" x 7.9" x 7.9" (340mm x 200mm x 200mm).

Item Code:
CNL-27336 (3000K)
CNL-27318 (6000K)



Compares to a 100W MH/HPS/HID, 300W incandescent, 100W CFL

30W 3300 LUMENS 4500K Corn Light E26 Medium Base UL	
Lumens: 3300	Fixture Color: White
Watts: 30	Fixture Material: Aluminum/PC
Light Color (Kelvin): 4500	Lifetime (Hours): >50,000
Voltage: 100-277V AC	Master Carton Quantity: 12
Base Type: E26 Medium	Master Carton Size: 20" x 15" x 11"
(also available in E39 Mogul)	(508mm x 381mm x 279mm)
Size in Inches: 3.66 x 8.26	Master Carton Wgt: 20.28 lbs (9.2 kg)
Size in mm: 93 x 2210	Warranty (Years): 5
CRI (Ra): >70	Luminous efficacy: 110 lm/W
LED Type: 2835 LED (228 pieces)	Working Temperature: -4°F to
Beam Angle: 360°	+113°F (-20°C to +45°C)
IP rating: 64	Certification: UL, CE, RoHS
Power Factor (PF): 0.90	Net Weight: 1.1 lbs (500 g)
	Notes: Suitable for use in enclosed luminaires, min. lamp compartment dimensions: 13.4" x 7.9" x 7.9" (340mm x 200mm x 200mm).

Item Code: CNL-27327



Compares to a 100W MH/HPS/HID, 300W incandescent, 100W CFL

Corn Lights

30W 4200 LUMENS 5000K Corn Light E26 Medium Base

Lumens: 4200	Fixture Color: White
Watts: 30	Fixture Material: Aluminum/PC
Light Color (Kelvin): 5000	Lifetime (Hours): 35,000
Voltage: 300-480V AC	Master Carton Quantity: 24
Base Type: E26 Medium	Master Carton Size: 21.85" x 18.1"
Size in Inches: 3.66 x 7.67	x 16.9" (555 x 460 x 430mm)
Size in mm: 93 x 195	Master Carton Wgt: 26.45 lbs (12 kg)
CRI (Ra): 80	Warranty (Years): 5
LED Type: 154 pieces of 2835	Luminous efficacy: 140 lm/W
Beam Angle: 360°	Working Temperature: -4°F to
IP rating: 20	+104°F (-20°C to +40°C)
Power Factor (PF): 0.9	Certification: CE, RoHS
	Net Weight: 0.75 lbs (0.34 kg)
	Notes: Internal driver and fan.

Item Code: **CNL-64803**



Compares to a 100W MH/HPS/HID, 60W CFL

40W 4400 LUMENS 6000K Corn Light E26/E39 Base UL

Lumens: 4400	Fixture Color: White
Watts: 40	Fixture Material: Polycarbonate
Light Color (Kelvin): 6000	Lifetime (Hours): >50,000
Voltage: 100-277V AC	Master Carton Quantity: 12
Base Type: E26 Medium or E39 Mogul	Master Carton Size: 20" x 15" x 12.2"
Size in Inches: 3.66 x 10.23	(508mm x 381mm x 310mm)
Size in mm: 93 x 260	Master Carton Wgt: 22 lbs (10 kg)
CRI (Ra): >70	Warranty (Years): 5
LED Type: Epistar 2835 (288 pcs)	Luminous efficacy: 110 lm/W
Beam Angle: 360°	Working Temperature: -4°F to
IP rating: 64	+113°F (-20°C to +45°C)
Power Factor (PF): >90%	Certification: UL, CE, RoHS
	Net Weight: 1.2 lbs (0.56 kg)
Notes: Has an internal fan for cool running. Suitable for use in enclosed luminaires, min. lamp compartment dimensions: 15" x 7.9" x 7.9" (380mm x 200mm x 200mm).	

Item Code:
CNL-26841 (E39)
CNL-70402-65 (E26)



Compares to a 150W MH/HPS/HID, 400W incandescent, 120W CFL

EXXON Lighting Corporation



Corn Lights

40W 5600 LUMENS 5000K Corn Light E26 Medium Base	
Lumens: 5600	Fixture Color: White
Watts: 40	Fixture Material: Aluminum/PC
Light Color (Kelvin): 5000	Lifetime (Hours): 35,000
Voltage: 3277-480V AC	Master Carton Quantity: 30
Base Type: E26 Medium	Master Carton Size: 26.77" x 21.25" x 16.92" (680 x 540 x 430mm)
Size in Inches: 4.2 x 8.3	
Size in mm: 106 x 210	Master Carton Wgt: 39.7 lbs (18 kg)
CRI (Ra): 80	Warranty (Years): 5
LED Type: 266 pieces of 2845	Luminous efficacy: 140 lm/W
Beam Angle: 360°	Working Temperature: -4°F to +104°F (-20°C to +40°C)
IP rating: 20	
Power Factor (PF): 0.9	Cert: ETL, DLC, LDL, CE, RoHS
	Net Weight: 1 lb (0.45 kg)
	Notes: Internal driver and fan.
	Other colors (K) available.

Item Code: **CNL-64804**



Compares to a 175W MH/HPS/HID, 75W CFL

60W 6600 LUMENS 6000K CL E26 or E39 Base UL DLC	
Lumens: 6600	Fixture Color: White
Watts: 60	Fixture Material: Polycarbonate
Light Color (Kelvin): 6000	Lifetime (Hours): >50,000
Voltage: 100-277V AC	Master Carton Quantity: 12
Base Type: E26 M/E39 Mogul	Master Carton Size: 20" x 15" x 13" (508mm x 381mm x 330mm)
Size in Inches: 3.54 x 10.43 (3.54 x 11.22)	Master Carton Wgt: 22 lbs (10 kg)
Size in mm: 90 x 265 (90 x 285 Mogul)	Warranty (Years): 5
CRI (Ra): >80	Luminous efficacy: 110 lm/W
LED Type: 2835 x 416 pieces	Working Temperature: -4°F to +113°F (-20°C to +45°C)
Beam Angle: 360°	Certification: UL, CE, RoHS, DLC
IP rating: 64	Net Weight: 1.5 lbs (0.70 kg)
Power Factor (PF): >90%	Notes: Has an internal Sunon fan for cool running. Suitable for use in enclosed luminaires, min. lamp compartment dimensions: 16.5" x 8.3" x 8.3" (420mm x 210mm x 210mm)

Item Code:
CNL-46029 (E26 Medium)
CNL-29514 (E39 Mogul)



Compares to a 175W MH/HPS, 500W incandescent, 150W CFL

Corn Lights

60W 8400 LUMENS 5000K Corn Light E26 Base ETL DLC

Lumens: 8400	Fixture Color: White
Watts: 60	Fixture Material: Aluminum/PC
Light Color (Kelvin): 5000	Lifetime (Hours): 35,000
Voltage: 277-480V AC	Master Carton Quantity: 15
Base Type: E26 Medium	Master Carton Size: 26.77" x 13.38" x
Size in Inches: 4.2 x 10.2	16.92" (680 x 340 x 430mm)
Size in mm: 106 x 260	Master Carton Wgt: 24.25 lbs (11 kg)
CRI (Ra): 80	Warranty (Years): 5
LED Type: 378 pieces of 2845	Luminous efficacy: 140 lm/W
Beam Angle: 360°	Working Temperature: -4°F to
IP rating: 20	+104°F (-20°C to +40°C)
Power Factor (PF): 0.9	Cert: ETL, DLC, LDL, CE, RoHS
	Net Weight: 1.08 lbs (0.49 kg)
	Notes: Internal driver and fan.
	Other colors (K) available.

Item Code: CNL-64806



Compares to a 175W MH/HPS, 120W CFL

80W 8800 LUMENS Corn Light E26 or E39 Base

Lumens: 8800	Fixture Color: White
Watts: 80	Fixture Material: PC/Aluminum
Light Color (Kelvin): 4000 or 5000	Lifetime (Hours): >50,000
Voltage: 100-300V AC	Master Carton Quantity: 12
Base Type: E26 M or E39 Mogul	Master Carton Size: 21.5" x 13.46" x
Size in Inches: 4.73 x 11.02	14.17" (456 x 342 x 360mm)
Size in mm: 120 x 280	Master Carton Wgt: 37 lbs (16.8 kg)
CRI (Ra): >80	Warranty (Years): 5
LED Type: 120 x 3030	Luminous efficacy:
Beam Angle: 360°	Working Temperature: -22°F to
IP rating: 44	+131°F (-30°C to +55°C)
Power Factor (PF): >0.9	Certification: cUL, RoHS
	Net Weight: 1.94 lbs (900 g)
	Notes: Has an internal fan for cool running.

Item Code: CNX-70802-95



Compares to a 175W-250W MH/HPS, 150W CFL

EXXON Lighting Corporation

EXXON
Lighting

Corn Lights

80W 9000 LUMENS 5700K Corn Light E39 Mogul Base UL	
Lumens: 9000	Fixture Color: White
Watts: 80	Fixture Material: Polycarbonate
Light Color (Kelvin): 5700	Lifetime (Hours): >50,000
Voltage: 100-277V AC	Master Carton Quantity: 12
Base Type: E39 Mogul	Master Carton Size: 24.8" x 18.5" x 12.6 (630mm x 470mm x 320mm)
Size in Inches: 4.9 x 10.62	
Size in mm: 125 x 270	Master Carton Wgt: 37.5 lbs (17.0 kg)
CRI (Ra): >70	Warranty (Years): 5
LED Type: 2835 x 560 pieces	Luminous efficacy: 113 lm/W
Beam Angle: 360°	Working Temperature: -4° F to +113° F (-20° C to +45° C)
IP rating: 64	
Power Factor (PF): >90%	Certification: UL, CE, RoHS
	Net Weight: 2.4 lbs (1.1 kg)
Notes: Also available in 3000K/4500K. Has an internal fan for cool running. Minimum lamp compartment dimensions (for enclosed fixtures): 16.5" x 9" x 9" (420mm x 230mm x 230mm)	

Item Code: CNL-38055



Compares to a 300W MH/HPS/HID, 600W incandescent, 200W CFL

80W 11000 LUMENS 5000K Corn Light E39 Base ETL DLC	
Lumens: 11000	Fixture Color: White
Watts: 80	Fixture Material: Aluminum/PC
Light Color (Kelvin): 5000	Lifetime (Hours): 35,000
Voltage: 277-480V AC	Master Carton Quantity: 15
Base Type: E39 Mogul	Master Carton Size: 26.77" x 14.17" x 16.92" (680 x 360 x 430mm)
Size in Inches: 4.2 x 11	
Size in mm: 106 x 280	Master Carton Wgt: 26.45 lbs (12 kg)
CRI (Ra): 80	Warranty (Years): 5
LED Type: 490 pieces of 2845	Luminous efficacy: 138 lm/W
Beam Angle: 360°	Working Temperature: -4° F to +104° F (-20° C to +40° C)
IP rating: 20	
Power Factor (PF): 0.9	Cert: ETL, DLC, LDL, CE, RoHS
	Net Weight: 1.3 lbs (0.585 kg)
	Notes: Internal driver and fan.
	Other colors (K) available.

Item Code: CNL-64808



Compares to a 320W MH/HPS/HID, 150W CFL

Corn Lights

100W 11500 LUMENS 5700K CL E39 Mogul Base UL DLC

Lumens: 11500	Fixture Color: White
Watts: 100	Fixture Material: PC/Aluminum
Light Color (Kelvin): 5700	Lifetime (Hours): >35,000
Voltage: 100-277V AC	Master Carton Quantity: 6
Base Type: E39 Mogul	Master Carton Size: 18" x 13" x 13"
Size in Inches: 4.92 x 11.42	(457mm x 330mm x 330mm)
Size in mm: 125 x 290	Master Carton Wgt: 19.2 lbs (8.7 kg)
CRI (Ra): >70	Warranty (Years): 5
LED Type: 2835 SMD x728 pieces	Luminous efficacy: 115 lm/W
Beam Angle: 360°	Working Temperature: -4°F to +113°F (-20°C to +45°C)
IP rating: 64	
Power Factor (PF): >0.90	Certification: UL, DLC
	Net Weight: 2.6 lbs (1.2 kg)
Notes: Has two internal fans for cool running. Minimum lamp compartment dimensions (for enclosed fixtures): 15.9" x 5.8" (405mm x 147mm).	

Item Code: CNL-41097



Compares to a 175W-250W MH/HPS, 150W CFL

100W 11000 lumens 5500K LED Corn Light E39 Base UL

Lumens: 11000	Fixture Color: White/Aluminum
Watts: 100	Fixture Material: Aluminum/PC
Light Color (Kelvin): 5500	Lifetime (Hours): >50,000
Voltage: 100-277V AC	Master Carton Quantity: 12
Base Type: E39 Mogul	Master Carton Size: 20.7" x 17.1" x 12.2"
Size in Inches: 4.73 dia. x 11.77	(525 x 435 x 310mm)
Size in mm: 120 dia. x 299	Master Carton Wgt: 35.3 lbs (16 kg)
CRI (Ra): >80	Warranty (Years): 5
LED Type: 144 x 3030	Luminous efficacy: 110 lm/W
Beam Angle: 360°	Working Temperature: -4°F to +122°F (-20°C to +50°C)
IP rating: 44	
Power Factor (PF): >0.9	Certification: CE, ETL, RoHS, FCC, DLC
	Net Weight: 4.2 lbs (1.9 kg)
Notes: Has an internal fan for cool running. 2700K-6500K available.	

Item Code: CNX-71002-95



Compares to a 300W MH/HPS/HID, 600W incandescent, 200W CFL

EXXON Lighting Corporation

EXXON
Lighting

Corn Lights

100W 14000 LUMENS 5000K Corn Light E39 Base	
Lumens: 14000	Fixture Color: White
Watts: 100	Fixture Material: Aluminum/PC
Light Color (Kelvin): 5000	Lifetime (Hours): 35,000
Voltage: 277-480V AC	Master Carton Quantity: 12
Base Type: E39 Mogul	Master Carton Size: 12.5" x 24.5" x 20" (317mm x 622mm x 508mm)
Size in Inches: 5.2 x 10.62	
Size in mm: 132mm x 270mm	Master Carton Wgt: 32.6 lbs (14.8 kg)
CRI (Ra): 80	Warranty (Years): 5
LED Type: 574 pieces of 2845	Luminous efficacy: 110 lm/W
Beam Angle: 360°	Working Temperature: -4°F to +104°F (-20°C to +40°C)
IP rating: 20	
Power Factor (PF): 0.9	Certification:
	Net Weight: 2.06 lbs (937 g)
	Notes: Internal driver and fan. Other colors (K) available.

Item Code: CNL-64810



Compares to a 400W MH/HPS/HID, 200W CFL

120W 14400 lumens 5500K LED Corn Light E39 Base UL	
Lumens: 14400	Fixture Color: White/Aluminum
Watts: 120	Fixture Material: Aluminum/PC
Light Color (Kelvin): 5500	Lifetime (Hours): >50,000
Voltage: 100-277V AC	Master Carton Quantity: 12
Base Type: E39 Mogul	Master Carton Size: 20.7" x 17.1" x 12.2" (525 x 435 x 310mm)
Size in Inches: 4.73 dia. x 13.31	
Size in mm: 120 dia. x 338	Master Carton Wgt: 35.3 lbs (16 kg)
CRI (Ra): >80	Warranty (Years): 5
LED Type: 168 x 3030	Luminous efficacy: 120 lm/W
Beam Angle: 360°	Working Temperature: -4°F to +122°F (-20°C to +50°C)
IP rating: 44	
Power Factor (PF): >0.9	Cert: CE, ETL, RoHS, FCC, DLC
	Net Weight: 4 lbs (1.8 kg)
	Notes: Has an internal fan for cool running. 2700K-6500K available.

Item Code: CNX-71202-95



Compares to a 320W MH/HPS/HID, 150W CFL

Corn Lights

120W 13500 LUMENS 5700K CL E39 Mogul Base UL DLC	
Lumens: 13500	Fixture Color: White
Watts: 120	Fixture Material: Aluminum fin heat sink+MPCB+PBT base (fire proof)
Light Color (Kelvin): 5700	
Voltage: 100-277V AC	Lifetime (Hours): >50,000
Base Type: E39 Mogul	Master Carton Quantity: 6
Size in Inches: 4.9 x 12.2	M Carton Size: 18.3" x 12.8" x 14.2" (465mm x 325mm x 360mm)
Size in mm: 125 x 310	
CRI (Ra): >70	Master Carton Wgt: 20.6 lbs (9.34 kg)
LED Type: 2835 SMD x 896 pieces	Warranty (Years): 5
Beam Angle: 360°	Luminous efficacy: 113 lm/W
IP rating: 64	Working Temperature: -4°F to +113°F (-20°C to +45°C)
Power Factor (PF): >0.90	
	Certification: UL, DLC
	Net Weight: 2.9 lbs (1.3 kg)

Item Code: CNL-41277



Compares to a 500W MH/HPS, 800W incandescent, 300W CFL

Notes: Has two internal fans for cool running. Minimum lamp compartment dimensions (for enclosed fixtures): 17.3" x 10.2" x 10.2" (440mm x 260mm x 260mm)

120W 16800 LUMENS 5000K Corn Light E39 Base	
Lumens: 16800	Fixture Color: White
Watts: 120	Fixture Material: Aluminum/PC
Light Color (Kelvin): 3000/4000 /6000	
Voltage: 300-480V AC	Lifetime (Hours): 35,000
Base Type: E39 Mogul	Master Carton Quantity: 12
Size in Inches: 5.2 x 10.62	Master Carton Size: 26.4" x 13.5" x 20.5" (670 x 343 x 520mm)
Size in mm: 132 x 270	
CRI (Ra): 80	Master Carton Wgt: 35.3 lbs (16 kg)
LED Type: 574 pieces of 2845	Warranty (Years): 5
Beam Angle: 360°	Luminous efficacy: 140 lm/W
IP rating: 20	Working Temperature: -4°F to +104°F (-20°C to +40°C)
Power Factor (PF): 0.9	
	Certification: CE, RoHS, FCC, LDL
	Net Weight: 2.3 lbs (1.01 kg)
	Notes: Internal driver and fan.

Item Code: CNL-64812



Compares to a 500W MH/HPS/HID,

EXXON Lighting Corporation



Corn Lights

150W 20000 LUMENS 6000K CL E39 Mogul Base UL DLC	
Lumens: 20000	Fixture Color: Silver/White
Watts: 150	Material: Aluminum/MPCB/PBT base
Light Color (Kelvin): 6000	Lifetime (Hours): >50,000
Voltage: 100-277V AC	Master Carton Quantity: 12
Base Type: E39 Mogul	M Carton Size: 24.8" x 18.5" x 15"
Size in Inches: 4.9 x 13.2	(630mm x 470mm x 381mm)
Size in mm: 125 x 335	Master Carton Wgt: 45.4 lbs (20.6 kg)
CRI (Ra): >70	Warranty (Years): 5
LED Type: 2835 SMD x 1064 pieces	Luminous efficacy: 110 lm/W
Beam Angle: 360°	Working Temperature: -4°F to
IP rating: 64	+113°F (-20°C to +45°C)
Power Factor (PF): >0.90	Certification: UL, DLC
	Net Weight: 1.9 lbs (0.86 kg)
<p>Notes: Replaces 450-500W MH/HPS. Has two internal fans for cool running. Minimum lamp compartment dimensions (for enclosed fixtures): 18.5" x 16.2" x 16.2" (470mm x 270mm x 270mm).</p>	

Item Code: CNL-51527



Compares to a 500W MH/HPS, 400W CFL, 1000W Incandescent



Post/Garden Lights

Available in a variety of configurations, wattages, lumens and colors (Kelvin)

30W 1700 LUMENS 6000K POST Light

Lumens: 1700	Fixture Color: Gray/Black
Watts: 30	Fixture Material: Polycarbonate
Light Color (Kelvin): 6000	Lifetime (Hours): >30,000
Voltage: 100-277V AC	Carton Quantity: 1
Base Type: Cable	Carton Size: 19.29" x 18.5" x 23.03"
Size in Inches: 15.74 x 18.5	(490mm x 470mm x 585mm)
Size in mm: 400 x 270	Carton Weight: 15.52 lbs (7.04 kg)
CRI (Ra): >70	Warranty (Years): 3
LED Type: CREE (24 pieces)	Luminous efficacy:
Beam Angle: 360°	Working Temperature: -13°F to
IP rating: 65	+122°F (-25°C to +50°C)
Power Factor (PF): >0.9 THD<15%	Certification: CE, RoHS
	Net Weight: 11 lbs (4.99 kg)
	Notes: Installation Pole Diameter 2.362"(60mm)

Item Code: GDN-26508



Item Code:

STL-69206 60W, 7200lm
 STL-69208 80W, 9600lm
 STL-69210 100W, 12000lm
 STL-69212 120W, 14400lm
 STL-69215 150W, 18000lm
 STL-69218 180W, 21600lm
 STL-69220 200W, 24000lm
 STL-69224 240W, 28500lm

60-240W 7200-28500 LUMENS 5000K POST TOP Light

Lumens: 18000	Fixture Color: White
Watts: 150	Fixture Material: Aluminum/PC
Light Color (Kelvin): 5000	Lifetime (Hours): >50,000
Voltage: 100-277V AC	Master Carton Quantity: 6
Base Type: E39 Mogul	M Carton Size: 21.38" x 16.97" x 14.65"
Size in Inches: 14.72 x 5.51	(543mm x 431mm x 372mm)
Size in mm: 374 x 140	Master Carton Wgt: 29.92 lbs (13.6 kg)
CRI (Ra): >80	Warranty (Years): 5
LED Type: Samsung 5630 x 565	Luminous efficacy: 120 lm/W
Beam Angle: 360°	Working Temperature: -20°F to
IP rating: 64	+140°F (-29°C to +60°C)
Power Factor (PF): >0.90	Certification: UL, CE, RoHS, USDA
	Net Weight: 3.6 lbs (1.64 kg)
	Notes: Compares to a 600/700W MH/HPS, 300W CFL



60W compares to a 175W MH/HPS/HID

EXXON Lighting Corporation



Post Top Lights

40W or 60W 5700K Corn Light E26 or E39 Base ETL	
Lumens: 5600 (40W) or 8400 (60W)	Fixture Color: White
Watts: 40 or 60	Fixture Material: Aluminum/PC
Light Color (Kelvin): 5700 except * 5000K	Lifetime (Hours): >35,000
	Master Carton Quantity: 12
Voltage: 100-300V AC	Master Carton Size: 26.4" x 13.5" x 20.5" (670mm x 343mm 520mm)
Base Type: E26 M or E39 Mogul	Master Carton Wgt: 21.4 lbs (9.7 kg)
Size in Inches: 4.17 dia. x 7.08	Warranty (Years): 5
Size in mm: 106 dia. x 180	Luminous efficacy: 140 lm/W
CRI (Ra): >80	Working Temperature: -4°F to +104°F (-20°C to +40°C)
LED Type: 2835 Epistar Chip	
Beam Angle: 360°	Certification:
IP rating: 40	Net Weight: 1.1 lb (0.5 kg)
Power Factor (PF): >0.95	Notes: 300-480V AC available.

Item Code:

- CNL-64053 - 40W, E39**
- CNL-66036 - 60W, E26**
- CNL-66049 - 60W, E39**
- * CNL-64043 - 40W, E26 5000K**



40W compares to a 175W MH/HPS, 75W CFL. 60W compares to a 175W MH/HPS/HID, 150W CFL



Street Lights - Retrofit Lamps

40W 5400 lumens 5500K/2200K/1900K Street light UL USDA

Lumens: 5400	Fixture Color:
Watts: 40	Fixture Material: PC/Aluminum
Light Color (Kelvin): 5000/2200 /1900	Lifetime (Hours): >50,000
	Carton Quantity: 12
Voltage: 100-277V AC	Carton Size: 21.25" x 16.14" x 13"
Base Type: E26 Medium	(540mm x 410mm x 330mm)
Size in Inches: 9.88 x 3.54	Carton Weight: 26.45 lbs (12 kg)
Size in mm: 251 x 90	Warranty (Years): 5
CRI (Ra): >80	Luminous efficacy: 135 lm/W
LED Type: Samsung 5630 x 220	Working Temperature: -20°F to +140°F (-29°C to +60°C)
Beam Angle: 180°	
IP rating: 64	Cert: UL, CE, RoHS, FCC, USDA
Power Factor (PF): 0.9	Net Weight: 0.79 lbs (360 g)
	Notes:

Item Code:

CNL-54055 (5000K)
CNL-54022 (2200K)
CNL-54019 (1900K)
590nm Turtle Friendly)



Compares to a 175W MH/HPS/HID

5000K Street Light 180 DEGREE E26/E39 UL

Lumens: 3400 or 4500 or 6750	Fixture Color: Black
Watts: 27, or 36 or 54	Fixture Material: Magnesium
Light Color (Kelvin): 5000	Alloy+AL+PC
Voltage: 100-277V AC	Lifetime (Hours): >50,000
Base Type: E26 (E39 for STL-70542-95 *)	Carton Quantity: 8
	Carton Size:
Size in Inches: 9.6 x 4.4 x 3.1	Carton Weight:
Size in mm: 239.5 x 112.8 x 80.3	Warranty (Years): 5
CRI (Ra): >70	Luminous efficacy: 125 lm/W
LED Type: Philips 3030 2D	Working Temperature: -4°F to +113°F (-20°C to +45°C)
Beam Angle: 90 x 150° (Type III)	
IP rating: 51	Cert: cULus (DLC for STL-70542-95 only)
Power Factor (PF): >0.9	Net Weight: 1.65 lbs (0.75 kg)
	Notes:

Item Code:

STL-70272-65 (27W 3400lm)
STL-70362-65 (36W 4500lm)
STL-70542-65 (54W 6750lm)
STL-70542-95 (54W 6750lm *)



27W compares to a 100W MH, 60W CFL
 36W compares to a 150W MH, 80W CFL
 54W compares to a 175W MH, 120W CFL

EXXON Lighting Corporation



Street Lights - Retrofit Lamps

75W 9400 lumens 5000K Street Light 180° E39 UL DLC	
Lumens: 9400	Fixture Color: Black
Watts: 75	Fixture Material: Mag Alloy+AL+PC
Light Color (Kelvin): 5000	Lifetime (Hours): >50,000
Voltage: 100-277V AC	Carton Quantity: 8
Base Type: E39 Mogul	Carton Size: 26" x 14" x 9.4" (660mm x 355mm x 240mm)
Size in Inches: 11.8 x 5.4 x 3.4	
Size in mm: 290.5 x 135.5 x 86.6	Carton Weight: 28.9 lbs (13.1 kg)
CRI (Ra): >70	Warranty (Years): 5
LED Type: Philips 3030 2D x 141	Luminous efficacy: 125 lm/W
Beam Angle: 90 x 150° (Type III)	Working Temperature: -4° F to +113° F (-20° C to +45° C)
IP rating: 51	
Power Factor (PF): >0.9	Certification: cULus, DLC
	Net Weight: 2.86 lbs (1.3 kg)
	Notes:

Item Code:
STL-70752-95 (75W)
STL-70952-95 (95W)



75W compares to a 250W MH, 150W CFL,
 95W compares to a 400W MH, 200W CFL,

100W 12000 Lumens 5500K Street Light 180° E39 Mogul UL	
Lumens: 12000	Fixture Color: Gray/Silver
Watts: 100	Fixture Material: PC/Aluminum
Light Color (Kelvin): 5500	Lifetime (Hours): >50,000
Voltage: 100-277V AC	Carton Quantity: 12
Base Type: E39 Mogul	Carton Size:
Size in Inches: 10.78 x 4.44	Carton Weight: 29.38 lbs (13.32 kg)
Size in mm: 277 x 110	Warranty (Years): 5
CRI (Ra): >80	Luminous efficacy: 125 lm/W
LED Type: Samsung 3030 x 168	Working Temperature:
Beam Angle: 180°	Certification: UL, CE, RoHS, DLC
IP rating: 40	Net Weight: 2.42 lbs (1.1 kg)
Power Factor (PF): 0.9	Notes: Replaces Has two fans for cool running.

Item Code: CNL-50039



Compares to a 400W MH/HPS/HID,
 200W CFL

Street Lights - Retrofit Lamps

115W 14380 lumens 5000K Street Light 180° E39 UL DLC

Lumens: 14380	Fixture Color: Black
Watts: 115	Fixture Material: Mag Alloy+AL+PC
Light Color (Kelvin): 5000	Lifetime (Hours): >50,000
Voltage: 100-277V AC	Carton Quantity: 8
Base Type: E39 Mogul	Carton Size: 26" x 14" x 9.4" (660mm x 355mm x 240mm)
Size in Inches: 11.8 x 5.4 x 3.4	
Size in mm: 290.5 x 135.5 x 86.6	Carton Weight: 29.5 lbs (13.4 kg)
CRI (Ra): >70	Warranty (Years): 5
LED Type: Philips 3030 2D x 141	Luminous efficacy: 125 lm/W
Beam Angle: 90 x 150° (Type III)	Working Temperature: -4°F to +113°F (-20°C to +45°C)
IP rating: 51	
Power Factor (PF): >0.9	Certification: cULus, DLC
	Net Weight: 2.86 lbs (1.3 kg)
	Notes:

Item Code: STL-71152-95



Compares to a 200W CFL, 400W MH



EXXON Lighting Corporation



Retrofit Lamps

5W 425 LUMENS 6000K Round Plate	
Lumens: 425	Fixture Color:
Watts: 5	Fixture Material: Aluminum -
Light Color (Kelvin): 6000	Strong magnets at the bottom of
Voltage: 100-300V AC	the PCB legs
Base Type: 2 wire	Lifetime (Hours): >50,000
Size in Inches: 1.97 dia.	Master Carton Quantity: 20
Size in mm: 50 dia.	Master Carton Size:
CRI (Ra):	Master Carton Weight:
LED Type: LED Board 10 x 5730	Warranty (Years): 3
Epistar	Luminous efficacy: 85 lm/W
Beam Angle: 180°	Working Temperature:
IP rating:	Certification: UL, CE, RoHS
Power Factor (PF):	Net Weight: 0.22 lbs (100 g)
	Notes:

Item Code: LEM-30585



Compares to an 8W CFL

7W 595 LUMENS 3000K/6000K Round Plate	
Lumens: 595	Fixture Color:
Watts: 7	Fixture Material: Aluminum -
Light Color (Kelvin): 3000/6000	Strong magnets at the bottom of
Voltage: 100-300V AC	the PCB legs
Base Type: 2 wire	Lifetime (Hours): >50,000
Size in Inches: 4.92 dia.	Master Carton Quantity: 50
Size in mm: 125 dia.	Master Carton Size:
CRI (Ra):	Master Carton Weight:
LED Type: LED Board 14 x 5730	Warranty (Years): 3
Epistar	Luminous efficacy:
Beam Angle: 180°	Working Temperature:
IP rating:	Certification: UL, CE, RoHS
Power Factor (PF):	Net Weight: 0.23 lbs (104 g)
	Notes:

Item Code: LEM-30738 (3000K)
Item Code: LEM-30792 (6000K)



Compares to an 14W CFL

Retrofit Lamps

12W 1020 LUMENS 6000K Round Plate

Lumens: 1020	Fixture Color:
Watts: 12	Fixture Material: Aluminum -
Light Color (Kelvin): 6000	Strong magnets at the bottom of the PCB legs
Voltage: 100-300V AC	
Base Type: 2 wire	Lifetime (Hours): >50,000
Size in Inches: 7.08 dia.	Master Carton Quantity: 50
Size in mm: 180 dia.	Master Carton Size:
CRI (Ra):	Master Carton Weight:
LED Type: LED Board 24 x 5730	Warranty (Years): 3
Epistar	Luminous efficacy: 85 lm/W
Beam Angle: 180°	Working Temperature:
IP rating:	Certification: UL, CE, RoHS
Power Factor (PF):	Net Weight: 0.33 lbs (150 g)
	Notes: Other colors (K) available

Item Code: LEM-31278



Compares to a 27W CFL

18W 1530 LUMENS 6000K Round Plate

Lumens: 1530	Fixture Color:
Watts: 18	Fixture Material: Aluminum -
Light Color (Kelvin): 6000	Strong magnets at the bottom of the PCB legs
Voltage: 100-300V AC	
Base Type: 2 wire	Lifetime (Hours): >50,000
Size in Inches: 9.65 dia.	Master Carton Quantity: 50
Size in mm: 245 dia.	Master Carton Size:
CRI (Ra):	Master Carton Weight:
LED Type: LED Board 36 x 5730	Warranty (Years): 3
Epistar	Luminous efficacy: 85 lm/W
Beam Angle: 180°	Working Temperature:
IP rating:	Certification: UL, CE, RoHS
Power Factor (PF):	Net Weight: 0.75 lbs (340 g)
	Notes: Other colors (K) available

Item Code: LEM-31827



Compares to a 40W CFL

EXXON Lighting Corporation



Retrofit Lamps

7W 595 LUMENS 6000K H Shape Plate	
Lumens: 595	Fixture Color:
Watts: 7	Fixture Material: Aluminum -
Light Color (Kelvin): 6000	Strong magnets at the bottom of
Voltage: 100-277V AC	the PCB legs
Base Type: 2 wire	Lifetime (Hours): >50,000
Size in Inches: 7.08 x 1.77	Master Carton Quantity: 50
Size in mm: 180 x 45	Master Carton Size:
CRI (Ra): 80	Master Carton Weight:
LED Type: SMD5730 (14 pieces)	Warranty (Years): 3
Beam Angle: 180°	Luminous efficacy: 85 lm/W
IP rating:	Working Temperature:
Power Factor (PF):	Certification: UL, CE, RoHS
	Net Weight: 0.4 lbs (180 g)
	Notes: Other colors (K) available

Item Code: LEM-30765

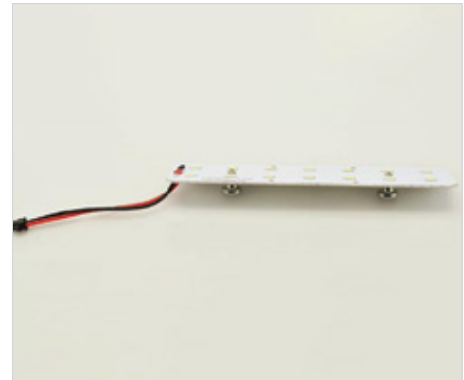

Compares to a 19W CFL

10W 850 LUMENS 6000K H Shape Plate	
Lumens: 850	Fixture Color:
Watts: 10	Fixture Material: Aluminum -
Light Color (Kelvin): 6000	Strong magnets at the bottom of
Voltage: 100-300V AC	the PCB legs
Base Type: 2 wire	Lifetime (Hours): >50,000
Size in Inches: 12.6 x 1.77	Master Carton Quantity: 50
Size in mm: 320 x 45	Master Carton Size:
CRI (Ra):	Master Carton Weight:
LED Type: LED Board 20 x 5730	Warranty (Years): 3
Epistar	Luminous efficacy: 85 lm/W
Beam Angle: 180°	Working Temperature:
IP rating:	Certification: UL, CE, RoHS
Power Factor (PF):	Net Weight: 0.51 lbs (230 g)
	Notes: Other colors (K) available

Item Code: LEM-31098



Compares to a 25W CFL

Retrofit Lamps

21W 1785 LUMENS 6000K H Shape Plate

Lumens: 1785	Fixture Color:
Watts: 21	Fixture Material: Aluminum -
Light Color (Kelvin): 6000	Strong magnets at the bottom of the PCB legs
Voltage: 100-277V AC	
Base Type: 2 wire	Lifetime (Hours): >50,000
Size in Inches: 21.65 x 1.97	Master Carton Quantity: 50
Size in mm: 550 x 50	Master Carton Size:
CRI (Ra): 80	Master Carton Weight:
LED Type: SMD5630 (42 pieces)	Warranty (Years): 3
Beam Angle: 180°	Luminous efficacy: 85 lm/W
IP rating:	Working Temperature:
Power Factor (PF): 0.9	Certification: UL, CE, RoHS
	Net Weight: 0.64 lbs (290 g)
	Notes: Other colors (K) available, 120V AC dimmable available.

Item Code: **LEM-32178**



Compares to a 55W CFL

9W 975 lumens 2800K/4200K/6000K Round Plate

Lumens: 975	Fixture Color:
Watts: 9	Fixture Material: Aluminum -
Light Color (Kelvin): 2800/4200 /6000	Strong magnets at the bottom of the PCB legs
Voltage: 120V AC	
Base Type: N/A	Lifetime (Hours): >30,000
Size in Inches: 5.2 dia.	Master Carton Quantity: 50
Size in mm: 132 dia.	Master Carton Size:
CRI (Ra): >70	Master Carton Weight:
LED Type: 2835	Warranty (Years): 3
Beam Angle: 180°	Luminous efficacy: 108 lm/W
IP rating:	Working Temperature:
Power Factor (PF): > 0.9	Certification: UL, CE, RoHS
	Net Weight: 0.29 lbs (132 g)
	Notes: Replaces a 22W circular fluorescent or 75W incandescent.

Item Code:
LEM-50975 (2800K)
LEM-50924 (4200K)
LEM-50916 (6000K)

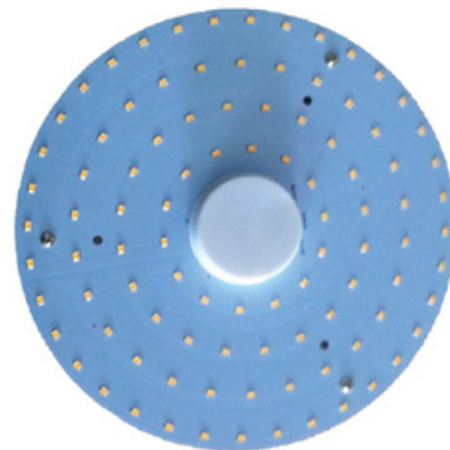

EXXON Lighting Corporation



Retrofit Lamps

1300 lumens 2800K/4200K/5000K/6000K Round Plate	
Lumens: 1300	Fixture Color:
Watts: 12	Fixture Material: Aluminum -
Light Color (Kelvin): 2800/4200 /5000/6000	Strong magnets at the bottom of the PCB legs
Voltage: 120V AC	Lifetime (Hours): >30,000
Base Type: N/A	Master Carton Quantity: 50
Size in Inches: 5.52 dia.	Master Carton Size:
Size in mm: 140 dia.	Master Carton Weight:
CRI (Ra): >70	Warranty (Years): 3
LED Type: 2835	Luminous efficacy: 108 lm/W
Beam Angle: 180°	Working Temperature:
IP rating:	Certification: UL, CE, RoHS
Power Factor (PF): > 0.9	Net Weight: 0.29 lbs (132 g)
	Notes: Replaces a 24W circular fluorescent or 120W incandescent.

Item Code:
LEM-51275 (2800K)
LEM-51256 (4200K)
LEM-51295 (5000K)
LEM-51216 (6000K)

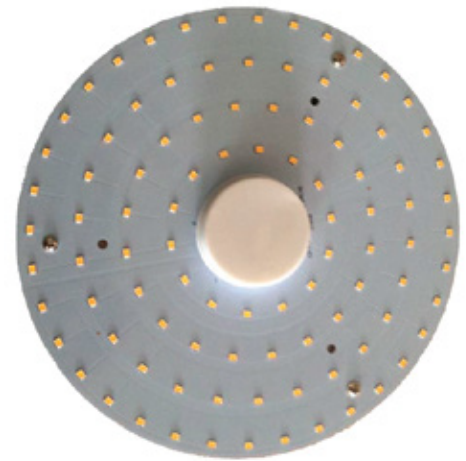

18W/24W 1950/2600 LUMENS 4000K Round Plate	
Lumens: 1950 or 2600	Fixture Color:
Watts: 18 or 24	Fixture Material: Aluminum -
Light Color (Kelvin): 4000	Strong magnets at the bottom of the PCB legs
Voltage: 120V AC	Lifetime (Hours): >30,000
Base Type: N/A	Master Carton Quantity: 50
Size in Inches: 7.87/11.81 dia. (18W/24W)	Master Carton Size:
Size in mm: 200/300 dia. (18W/24W)	Master Carton Weight:
CRI (Ra): >70	Warranty (Years): 3
LED Type: 2835	Luminous efficacy: 108 lm/W
Beam Angle: 180°	Working Temperature:
IP rating:	Certification: UL, CE, RoHS
Power Factor (PF): > 0.9	Net Weight: 0.29 lbs (132 g)
	Notes: Replaces a 36/48W CFL or 150/240W incandescent.

Item Code:
LEM-51863 (18W 1950 LM)
LEM-52491 (24W 2600LM)

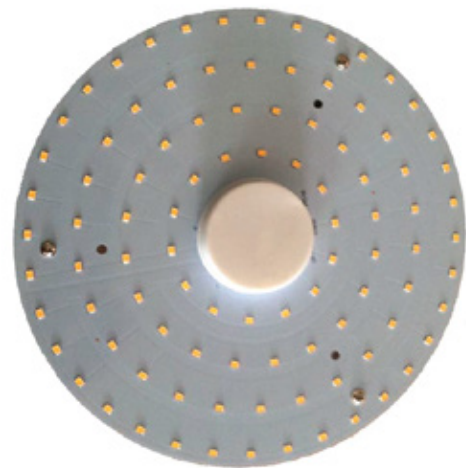

Retrofit Lamps

45W 3500 LUMENS 5500K LED retrofit kit UL DLC

Lumens: 3500	Fixture Color: N/A
Watts: 45	Fixture Material: Aluminum
Light Color (Kelvin): 5500	Lifetime (Hours): 70,000
Voltage: 90-305V AC	Master Carton Quantity: 6
Base Type: E39 Mogul (E26 Medium avail.)	M Carton Size: 22.83" x 13.39" x 18.9" (580mm x 340mm x 480mm)
Size in Inches: 4.7 x 4.7 x 1	Master Carton Wgt: 29.1 lbs (13.2 kg)
Size in mm: 120 x 120 x 25	Warranty (Years): 6
CRI (Ra): >70	Luminous efficacy: 95 lm/W
LED Type: Philips 3030	Working Temperature: -31°F to +131°F (-35°C to +55°C)
Beam Angle: 120°	
IP rating: 65	Certification: UL, DLC
Power Factor (PF): 0.98	Net Weight: 0.99 lbs (0.45 kg)

Item Code: LRK-44526



Compares to a 175W MH/HPS/HID, 100W CFL

Notes: 3000K/4100K available. E26/E39 mounting bracket included. See optional PGZ-61201 mounting bracket for DLC qualification.

80W 9900 LUMENS LED retrofit kit UL DLC

Lumens: 9900	Fixture Color: N/A
Watts: 80	Fixture Material: Aluminum
Light Color (Kelvin): 2000 or 5500	Lifetime (Hours): 70,000
Voltage: 90-295V AC (347-480V AC avail.)	Master Carton Quantity: 6
Base Type: E39 Mogul	M Carton Size: 22.83" x 13.39" x 18.9" (580mm x 340mm x 480mm)
Size in Inches: 6.8 x 4.9 x 1	Master Carton Wgt: 29.1 lbs (13.2 kg)
Size in mm: 173 x 125 x 25	Warranty (Years): 6
CRI (Ra): >70	Luminous efficacy: 95 lm/W
LED Type: Philips 3030	Working Temperature: -31°F to +131°F (-35°C to +55°C)
Beam Angle: 120° (15, 30, 45, 60 available)	Certification: UL, DLC
IP rating: 65	Net Weight: 1.28 lbs (0.58 kg)
Power Factor (PF): >0.98	Notes: 3000K/4100K/5000K available. E26/E39 mounting bracket included. See optional PGZ-61201 mtg bracket for DLC qualification.

Item Code: LRK-47514 (5500K)
Item Code: LRK-48720 (2000K)



Compares to a 320W MH/HPS/HID, 150W CFL

Retrofit Lamps

100W 12500 LUMENS 2200K or 5500K LED retrofit kit UL DLC	
Lumens: 12500	Fixture Color: N/A
Watts: 100 (+ 5W for driver)	Fixture Material: Aluminum
Light Color (Kelvin): 2200 or 5500	Lifetime (Hours): 70,000
Voltage: 90-295V AC or 480V AC	Master Carton Quantity: 6
Base Type: E39 Mogul (E26 Medium avail.)	Master Carton Size: 21" x 12" x 12" (533mm x 305mm x 305mm)
Size in Inches: 6.8 x 4.9 x 1	Master Carton Wgt: 29.1 lbs (13.2 kg)
Size in mm: 173 x 125 x 25	Warranty (Years): 6
CRI (Ra): >70	Luminous efficacy: 95 lm/W
LED Type: Philips 3030	Working Temperature: -31°F to
Beam Angle: 120° (15, 30, 45, 60 available)	+131°F (-35°C to +55°C)
IP rating: 65	Certification: UL, DLC
Power Factor (PF): >0.98	Net Weight: 1.28 lbs (0.58 kg)
	Notes: 3000K/4100K/5000K available. 480V available (LRK-41088). E26/E39 mounting bracket included. See optional PGZ-61201 mounting bracket for DLC qualification.

Item Code:
LRK-40089 (5500K)
LRK-41088 (5500K, 480V)



Compares to a 400W MH/HPS/HID, 200W CFL, 800W incandescent

120W 15000 LUMENS 5500K LED retrofit kit UL DLC	
Lumens: 15000	Fixture Color: N/A
Watts: 120	Fixture Material: Aluminum
Light Color (Kelvin): 5500	Lifetime (Hours): 70,000
Voltage: 90-305V AC (347-480V AC avail.)	Master Carton Quantity: 6
Base Type: E39 Mogul	M Carton Size: 22.83" x 13.39" x 18.9" (580mm x 340mm x 480mm)
Size in Inches: 6.8 x 4.9 x 1	Master Carton Wgt: 29.1 lbs (13.2 kg)
Size in mm: 173 x 125 x 25	Warranty (Years): 6
CRI (Ra): >70	Luminous efficacy: 95 lm/W
LED Type: Philips 3030	Working Temperature: -31°F to
Beam Angle: 120° (15, 30, 45, 60 available)	+131°F (-35°C to +55°C)
IP rating: 65	Certification: UL, DLC
Power Factor (PF): >0.98	Net Weight: 1.28 lbs (0.58 kg)
	Notes: 3000K/4100K/5000K available. E26/E39 mounting bracket included. See optional PGZ-61201 mtg bracket for DLC qualification.

Item Code: LRK-41277



Compares to a 500W MH/HPS/HID

Retrofit Lamps

150W 19000 LUMENS 5500K LED retrofit kit UL DLC

Lumens: 19000	Fixture Color: N/A
Watts: 150	Fixture Material: Aluminum
Light Color (Kelvin): 5500	Lifetime (Hours): 70,000
Voltage: 90-305V AC (347-480V AC avail.)	Master Carton Quantity: 1
Base Type: E39 Mogul (E26 Medium avail.)	M Carton Size: 16.5" x 12.6" x 6.7" (420mm x 320mm x 170mm)
Size in Inches: 10.4 x 4.8 x 1.5	Master Carton Wgt: 10 lbs (4.57 kg)
Size in mm: 264 x 122 x 38	Warranty (Years): 6
CRI (Ra): >70	Luminous efficacy: 95 lm/W
LED Type: Philips 3030	Working Temperature: -31°F to +131°F (-35°C to +55°C)
Beam Angle: 120° (15, 30, 45, 60 available)	Certification: UL, DLC
IP rating: 65	Net Weight: 1.87 lbs (0.85 kg)
Power Factor (PF): >0.98	Notes: 3000K/4100K/5000K available. E26/E39 mounting bracket included. See optional PGZ-61201 mtg bracket for DLC qualification.

Item Code: LRK-41592



Compares to a 550W MH/HPS/HID

200W 19000 LUMENS 5500K LED retrofit kit UL DLC

Lumens: 19000	Fixture Color: N/A
Watts: 200	Fixture Material: Aluminum
Light Color (Kelvin): 5500	Lifetime (Hours): 70,000
Voltage: 90-305V AC (347-480V AC avail.)	Master Carton Quantity: 1
Base Type: E39 Mogul	M Carton Size: 16.5" x 12.6" x 6.7" (420mm x 320mm x 170mm)
Size in Inches: 10.4 x 4.8 x 1.5	Master Carton Wgt: 10 lbs (4.57 kg)
Size in mm: 264 x 122 x 38	Warranty (Years): 6
CRI (Ra): >70	Luminous efficacy: 95 lm/W
LED Type: Philips 3030	Working Temperature: -31°F to +131°F (-35°C to +55°C)
Beam Angle: 120° (15, 30, 45, 60 available)	Certification: UL, DLC
IP rating: 65	Net Weight: 1.87 lbs (0.85 kg)
Power Factor (PF): >0.98	Notes: 3000K/4100K/5000K available. E26/E39 mounting bracket included. See optional PGZ-61201 mounting bracket for DLC qualification.

Item Code: LRK-42078



Compares to a 600W MH/HPS/HID

EXXON Lighting Corporation



Retrofit Lamps

240W 28000 LUMENS 5500K LED retrofit kit UL DLC	
Lumens: 28000	Fixture Color: N/A
Watts: 240	Fixture Material: Aluminum
Light Color (Kelvin): 5500	Lifetime (Hours): 70,000
Voltage: 100-277V AC	Carton Quantity: 1
Base Type: E39 Mogul	M Carton Size: 25.6" x 16.5" x 12.2"
Size in Inches: 10.2 x 6.2 x 1.8	(650mm x 420mm x 310mm)
Size in mm: 259 x 158 x 46	Master Carton Wgt: 44 lbs (20 kg)
CRI (Ra): >80	Warranty (Years): 6
LED Type: Philips 3030	Luminous efficacy: 125 lm/W
Beam Angle: 120° (15, 30, 45, 60 available)	Working Temperature: -4°F to +113°F (-20°C to +45°C)
IP rating: 65	Certification: UL, cUL, DLC
Power Factor (PF): >0.98	Net Weight: 8.4 lbs (3.8 kg)
	Notes: E26/E39 mounting bracket included. See optional PGZ-61201 mounting bracket for DLC qualification.

Item Code: LRK-62450



Compares to a 800W MH/HPS/HID, 600W CFL

480V 300W 47500 LUMENS 5500K LED retrofit kit UL DLC	
Lumens: 47500	Fixture Color: Gray
Watts: 300	Fixture Material: Aluminum
Light Color (Kelvin): 5500	Lifetime (Hours): 50,000
Voltage: 347-480V AC	Carton Quantity: 1
Base Type: E39 Mogul	Carton Size: 11.96" x 1.57" x 1.41"
Size in Inches: (15.75-18.11) x 10.23 x 3.62	(50mm x 40mm x 36mm)
	Carton Weight: 40.8 lbs (18.5 kg)
Size in mm: (400-460) x 260 x 92	Warranty (Years): 6
CRI (Ra): >80	Luminous efficacy: 130 lm/W
LED Type: Philips 3030	Working Temperature: -4°F to +113°F (-20°C to +45°C)
Beam Angle: 120°	
IP rating: 40	Certification: UL, DLC
Power Factor (PF): >0.90	Net Weight: 16.1 lbs (7.3 kg)
	Notes: Compares to a 800-1000W MH/HPS. E26/E39 mounting bracket included. See optional PGZ-61201 mounting bracket for DLC qualification.

Item Code: LRK-53048



Compares to a 1000W MH/HPS/HID

Retrofit Lamps

400W 38000 LUMENS 5500K LED retrofit kit UL DLC

Lumens: 38000	Fixture Color: N/A
Watts: 400	Fixture Material: Aluminum
Light Color (Kelvin): 5500	Lifetime (Hours): 70,000
Voltage: 90-305V AC	Carton Quantity: 1
Base Type: E39 Mogul	Carton Size: 16.1" x 13" x 7.9"
Size in Inches: 12.6 x 9.4 x 3	(410mm x 330mm x 200mm) [23.2"
Size in mm: 320 x 239 x 76	x 13.8" x 8.7" (590mm x 350mm x
CRI (Ra): >70	220mm) with power supply]
LED Type: Philips 3030	Carton Weight: 11.9 lbs (5.41 kg)
Beam Angle: 120° (15, 30, 45, 60	[20 lbs (9.08kg) with power supply]
available)	Warranty (Years): 6
IP rating: 65	Luminous efficacy: 95 lm/W
Power Factor (PF): >0.98	Working Temperature: -31°F to
	+131°F (-35°C to +55°C)
	Certification: UL, DLC
	Net Weight: 6.6 lbs (3 kg)

Item Code: LRK-44085



Compares to a 1000W MH/HPS/HID

Notes: 3000K/4100K/5000K available. E26/E39 mounting bracket included. See optional PGZ-61201 mounting bracket for DLC qualification.

480V 400W 47500 LUMENS 5500K LED retrofit kit UL DLC

Lumens: 47500	Fixture Color: N/A
Watts: 400	Fixture Material: Aluminum
Light Color (Kelvin): 5500	Lifetime (Hours): 70,000
Voltage: 347-480V AC	Carton Quantity: 1
Base Type: E39 Mogul	Carton Size: 19.7" x 15" x 6.7"
Size in Inches: 12.6 x 9.4 x 3	(500mm x 380mm x 170mm)
Size in mm: 320 x 239 x 76	Carton Weight: 23 lbs (10.43 kg)
CRI (Ra): >70	Warranty (Years): 6
LED Type: Philips 3030	Luminous efficacy: 130 lm/W
Beam Angle: 120° (15, 30, 45, 60	Working Temperature: -31°F to
available)	+131°F (-35°C to +55°C)
IP rating: 65	Certification: UL, CE, RoHS, DLC
Power Factor (PF): >0.90	Net Weight:
	Notes: 3000K/4100K/5000K available. E26/E39 mounting bracket included. See optional PGZ-61201 mounting bracket for DLC qualification.

Item Code: LRK-54048



480V

Compares to a 1000W MH/HPS/HID

EXXON Lighting Corporation

EXXON[™]
Lighting

Retrofit Lamps

480W 60000 LUMENS 5500K LED retrofit kit UL DLC	
Lumens: 60000	Fixture Color: Gray
Watts: 480	Fixture Material: Aluminum
Light Color (Kelvin): 5500	Lifetime (Hours): 50,000
Voltage: 100-277V AC	Carton Quantity: 2
Base Type: E39 Mogul	Carton Size: 20" x 15.75" x 14.2"
Size in Inches: 12.6 x 9.4 x 3	(510mm x 400mm x 360mm)
Size in mm: 320 x 239 x 76	Carton Weight: 44 lbs (20 kg)
CRI (Ra): >80	Warranty (Years): 6
LED Type: Philips	Luminous efficacy: 125 lm/W
Beam Angle: 120°	Working Temperature: -4° F to
IP rating: 40	+113° F (-20° C to +45° C)
Power Factor (PF): >0.9	Certification: UL, cUL, DLC
	Net Weight: 17.6 lbs (8 kg)
<small>Notes: 3000K/4100K/5000K available. E26/E39 mounting bracket included. See optional PGZ-61201 mounting bracket for DLC qualification (below).</small>	

Item Code: LRK-64819



Compares to a 1500W MH/HPS/HID, 1200W CFL

led retrofit KIT optional mounting bracket

For use with any LED Retrofit kit - required for DLC qualification.

Item Code: PGZ-61201



Spot Lights

33W 2800 LUMENS 6000K E26 PAR38

Lumens: 2800 (Dimmable available)	Fixture Color: White/Aluminum
Watts: 33	Fixture Material: PC/Aluminum
Light Color (Kelvin): 6000	Lifetime (Hours): >40,000
Voltage: 100-305V AC	Master Carton Quantity: 10
Base Type: E26 Medium (E39 Mogul avail.)	Master Carton Size: 29.7" x 12" x 10.4" (755mm x 305mm x 265mm)
Size in Inches: 4.8 (dia.) x 7.28 (L)	
Size in mm: 122 (dia.) x 185 (L)	Master Carton Wgt: 28.66 lbs (13 kg)
CRI (Ra): >75	Warranty (Years): 3
LED Type: CREE XP-E (18 pieces)	Luminous efficacy: 75-85 lm/W
Beam Angle: 45° (25° /60° /90° available)	Working Temperature: -22°F to +104°F (-30°C to +40°C)
IP rating: 33	Certification: UL, cUL, FCC
Power Factor (PF): 0.99	Net Weight: 2.31 lbs (1.05 kg)
	Notes: (3000/4500K Available)

Item Code: SPL-43329



EXXON Lighting Corporation



Spot Lights

12W 950lm 4000K PAR30 36° E26 120-277V	
Lumens: 950	Carton Quantity: 50
Watts: 12	Carton Size: 520 x 485 x 340mm
Light Color (Kelvin): 4000	Carton Weight: 11Kg
Voltage: 100-277	LED Type: SMD
Base Type: E26	Power Factor (PF): >0.8
Size in Inches: 3.54" x 3.62"	Fixture Material: PC/Aluminum
Size in mm: 90mm x 92mm	Warranty (Years): 2
CRI (Ra): >80	Luminous efficacy: 80lm/W
Beam Angle: 36°	Working Temperature (°F (°C):
IP rating: 20	-10~60C
Fixture Color: White	Certification:
Lifetime (Hours): 25000	Net Weight: 0.3lb 0.14Kg
	Notes:

Item Code: SPL-70122-64



16W 1250lm 4000K PAR38 36° E26 120-277V	
Lumens: 1250	Carton Quantity: 30
Watts: 16	Carton Size: 655 x 275 x 450
Light Color (Kelvin): 4000	Carton Weight: 12.5Kg
Voltage: 100-277	LED Type: SMD
Base Type: E26 Medium	Power Factor (PF): >0.8
Size in Inches: 4.76 x 5	Fixture Material: PC/Aluminum
Size in mm: 121 x 127	Warranty (Years): 2
CRI (Ra): >80	Luminous efficacy: 80lm/W
Beam Angle: 36°	Working Temperature (°F (°C):
IP rating: 20	-10~60C
Fixture Color: White	Certification:
Lifetime (Hours): 25000	Net Weight: 0.24Kg
	Notes:

Item Code: SPL-70162-64



Bulkhead Lights

8W 500 LUMENS 6000K Bulkhead 100-265V AC

Lumens: 500	Fixture Color: White
Watts: 8	Fixture Material: Aluminum
Light Color (Kelvin): 6000	Lifetime (Hours): >40,000
Voltage: 100-265V AC	Master Carton Quantity:
Base Type: 3 Wire	Master Carton Size:
Size in Inches: 3.85 x 6.1 x 2.48	Master Carton Weight:
Size in mm: 98 x 155 x 63	Warranty (Years): 3
CRI (Ra): 80	Luminous efficacy:
LED Type: Samsung	Working Temperature:
Beam Angle: 180°	Certification:
IP rating: 65	Net Weight: 0.86 lbs (390 g)
Power Factor (PF):	Notes:

Item Code: CNF-23817



Compares to a 25W MH/HPS/HID, 20W CFL, or 50W Incandescent

8W 500 LUMENS 6500K Bulkhead Round 120V AC

Lumens: 500	Fixture Color: White
Watts: 8	Fixture Material: Aluminum
Light Color (Kelvin): 6500	Lifetime (Hours): >40,000
Voltage: 120V AC	Master Carton Quantity:
Base Type: 3 Wire	Master Carton Size:
Size in Inches: 6.73 x 3.03	Master Carton Weight:
Size in mm: 171 x 77	Warranty (Years): 3
CRI (Ra): 80	Luminous efficacy:
LED Type: Lextar	Working Temperature:
Beam Angle: 180°	Certification: CE, RoHS
IP rating: 65	Net Weight: 0.98 lbs (444 g)
Power Factor (PF):	Notes:

Item Code: CNF-25419



Compares to a 25W MH/HPS/HID, 20W CFL, or 50W Incandescent

EXXON Lighting Corporation



Down Lights

10.5W 120V 650lm (dimmable) 4" Can Light Replacement

Lumens: 650 (Dimmable)	Fixture Color: White
Watts: 10.5	Fixture Material: Aluminum
Light Color (Kelvin): 3000/4000 5000	Lifetime (Hours): >36,000 Master Carton Quantity: 40
Voltage: 120V AC	Master Carton Size: 22.2" x 11.6" x 16.1 (565 x 295 x 410mm)
Base Type: E26 (Medium)	
Size in Inches: 5.04 x 2.91 Approx	Master Carton Wgt: 16.75 lbs (7.6 kg)
Size in mm: 128 x 74	Warranty (Years): 3
CRI (Ra): >90	Luminous efficacy: 62 lm/W
LED Type: Samsung	Working Temperature:
Beam Angle: 101°	Certification: cULus, Energy Star, FCC, T24
IP rating: N/A (UL wet location listed)	Net Weight: 0.35 lbs (160 g)
Power Factor (PF): >0.9	Notes:

Item Code:
CNF-64103 - 3000K
CNF-64104 - 4000K
CNF-64105 - 5000K



Compares to a 30W MH/HPS/HID, 25W CFL, 70W Incandescent

12.5W 120V 850lm (dimmable) 5/6" Can Light Replacement

Lumens: 850 (Dimmable)	Fixture Color: White
Watts: 12.5	Fixture Material: Aluminum
Light Color (Kelvin): 3000/4000 /5000	Lifetime (Hours): >36,000 Master Carton Quantity: 10
Voltage: 120V AC	Master Carton Size: 16.1" x 7.8" x 18.5 (410mm x 212mm x 470mm)
Base Type: E26 (Medium)	
Size in Inches: 7.4 x 3.5 Approx	Master Carton Wgt: 8.92 lbs (4.05 kg)
Size in mm: 188 x 89	Warranty (Years): 3
CRI (Ra): >90	Luminous efficacy: 68 lm/W
LED Type: Samsung	Working Temperature:
Beam Angle: 101°	Cert: cULus, Energy Star, FCC, T24
IP rating: N/A (UL wet location listed)	Net Weight: 0.55 lbs (248 g)
Power Factor (PF): >0.9	Notes:

Item Code:
CNF-61203 - 3000K
CNF-61204 - 4000K
CNF-61205 - 5000K



Compares to a 40W MH/HPS/HID, 30W CFL, 100W Incandescent

Down Lights

14.5W 120V 1100lm (dimmable) 5/6" Can Light Replacement

Lumens: 1100 (Dimmable)	Fixture Color: White
Watts: 14.5	Fixture Material: Aluminum
Light Color (Kelvin): 3000/4000 5000	Lifetime (Hours): >36,000 Master Carton Quantity: 10
Voltage: 120V AC	Master Carton Size: 16.1" x 7.8" x 18.5 (410mm x 212mm x 470mm)
Base Type: E26 (Medium)	Master Carton Wgt: 8.92 lbs (4.05 kg)
Size in Inches: 7.4 x 3.5 Approx	Warranty (Years): 3
Size in mm: 188 x 89	Luminous efficacy: 76 lm/W
CRI (Ra): >90	Working Temperature:
LED Type: Samsung	Cert: cULus, Energy Star, FCC, T24
Beam Angle: 101°	Net Weight: 0.55 lbs (248 g)
IP rating: N/A (UL wet location listed)	Notes:
Power Factor (PF): >0.9	

Item Code:
CNF-60123 - 3000K
CNF-60124 - 4000K
CNF-60125 - 5000K



Compares to a 50W MH/HPS/HID, 35W CFL, 130W Incandescent

15W 120V 1060lm (dimmable) 6" DISK Light Replacement

Lumens: 1060 (Dimmable)	Fixture Color: White
Watts: 15	Fixture Material: Aluminum
Light Color (Kelvin): 3000/4000 /5000	Lifetime (Hours): >36,000 Master Carton Quantity: 40
Voltage: 120V AC	Master Carton Size: 17.7" x 15.7" x 15.7" (450 x 400 x 400mm)
Base Type: E26 (Medium) J-Box pigtail incl.	Master Carton Wgt: 24.5 lbs (11.1 kg)
Size in Inches: 7.4 x 0.9	Warranty (Years): 5
Size in mm: 188 x 23	Luminous efficacy: 61 lm/W
CRI (Ra): >90	Working Temperature:
LED Type: Samsung	Cert: cULus, Energy Star, FCC, T24
Beam Angle: 101°	Net Weight: 0.57 lbs (260 g)
IP rating: N/A (UL wet location listed)	Notes:
Power Factor (PF): >0.9	

Item Code:
CNF-61503 - 3000K
CNF-61504 - 4000K



Compares to a 50W MH/HPS/HID, 35W CFL, 120W Incandescent

EXXON Lighting Corporation



Down Lights

18W 1480 LUMENS 5000K Down Light	
Lumens: 1480 (dimnable)	Fixture Color: White
Watts: 18	Fixture Material: PC/Aluminum
Light Color (Kelvin): 5000	Lifetime (Hours): >30,000
Voltage: 100-277V AC	Master Carton Quantity: 20
Base Type: 2 Wire	M Carton Size: 27.8" x 12.6" x 11"
Size in Inches: 8.86 x 0.4 (Cutout 7.87)	(710mm x 320mm x 280mm)
Size in mm: 220 x 10 (Cutout 200)	Master Carton Wgt: 27.89 lbs (12.65 kg)
CRI (Ra): >80	Warranty (Years): 3
LED Type: 90 x 2835	Luminous efficacy: 70-80 lm/W
Beam Angle: 111°	Working Temperature: -4° F to +122° F (-20° C to +50° C)
IP rating:	Certification: CE, RoHS
Power Factor (PF): 0.94	Net Weight: 1.29 lbs (0.58 kg)
	Notes: Yellow/Purple/Grey 0-10v dimnable

Item Code: CNF-51744



Compares to a 55W MH/HPS/HID, 35W CFL, 150W Incandescent



Plug-in Lights

Available in a variety of voltages, wattages, lumens, colors (Kelvin) and base types

5W 500 LUMENS G24D 2 Pin 100-277v AC UL

Lumens: 500	Fixture: Color: White
Watts: 5	Fixture Material: PC/Aluminum
Light Color (Kelvin): 3000	Lifetime (Hours): 50,000
Voltage: 100-277V AC	Master Carton Quantity: 50
Base Type: G24D - 2 Pin	M Carton Size: 11.02" x 9.84" x 9.84"
Size in Inches: 1.77 x 4.84	(280mm x 250mm x 250mm)
Size in mm: 45 x 123	Master Carton Wgt: 20.3 lbs (9.2 kg)
CRI (Ra): >70	Warranty (Years): 5
LED Type: Epistar SMD2835 x 48 pieces	Luminous efficacy: 100 lm/W
Beam Angle: 360°	Working Temperature: -4°F to +113°F (-20°C to +45°C)
IP rating: 64	Certification: UL, cUL
Power Factor (PF): >0.90	Net Weight: 0.26 lbs (0.12 kg)
	Notes: Old ballast should be removed as an over-voltage may occur.

Item Code: PGL-60523



Compares to 40W incandescent, 15W CFL

9W 990 LUMENS G24Q 4 Pin 100-277v AC UL

Lumens: 990	Fixture Color: White
Watts: 9	Fixture Material: PC/Aluminum
Light Color (Kelvin): 3000, 4000 or 6000	Lifetime (Hours): 50,000
Voltage: 100-277V AC	Master Carton Quantity: 50
Base Type: G24Q - 4 Pin	M Carton Size: 11.81" x 9.45" x 9.65"
Size in Inches: 1.77 x 5.43	(300mm x 240mm x 245mm)
Size in mm: 45 x 138	Master Carton Wgt: 24.25lbs (11 kg)
CRI (Ra): >70	Warranty (Years): 5
LED Type: Epistar SMD2835 x 84 pieces	Luminous efficacy: 110 lm/W
Beam Angle: 360°	Working Temperature: -4°F to +113°F (-20°C to +45°C)
IP rating: 64	Certification: UL, cUL
Power Factor (PF): >0.90	Net Weight: 0.3 lbs (0.14 kg)
	Notes: Old ballast should be removed as an over-voltage may occur.

Item Code:
 PGL-60943 - 3000K
 PGL-60944 - 4000K
 PGL-60946 - 6000K
 PGL-60924 - (4000K 2-Pin)



Compares to 80W incandescent, 25W CFL

EXXON Lighting Corporation



Plug-in Lights

12W 1320 LUMENS G24D 2 Pin 100-277v AC UL	
Lumens: 1320	Fixture Color: White
Watts: 12	Fixture Material: PC/Aluminum
Light Color (Kelvin): 4000 or 5000	Lifetime (Hours): 50,000 Master Carton Quantity: 50
Voltage: 100-277V AC	M Carton Size: 13.78" x 9.84" x 9.84"
Base Type: G24D - 2 Pin	(350mm x 250mm x 250mm)
Size in Inches: 1.77 x 6.22	Master Carton Wgt: 26.9 lbs (12.2 kg)
Size in mm: 45 x 158	Warranty (Years): 5
CRI (Ra): >70	Luminous efficacy: 95-110 lm/W
LED Type: Epistar SMD2835 x 98 pieces	Working Temperature: -4°F to +113°F (-20°C to +45°C)
Beam Angle: 360°	Certification: UL, cUL
IP rating: 64	Net Weight: 0.35 lbs (0.16 kg)
Power Factor (PF): >0.90	Notes: Old ballast should be removed as an over-voltage may occur.

Item Code:
PGL-61224 - 4000K
PGL-61225 - 5000K



Compares to 100W incandescent, 30W CFL

12W 1320 LUMENS G24Q 4 Pin 100-277v AC UL	
Lumens: 1320	Fixture Color: White
Watts: 12	Fixture Material: PC/Aluminum
Light Color (Kelvin): 4000 to 6000	Lifetime (Hours): 50,000 Master Carton Quantity: 50
Voltage: 100-277V AC	M Carton Size: 13.78" x 9.84" x 9.84"
Base Type: G24Q - 4 Pin	(350mm x 250mm x 250mm)
Size in Inches: 1.77 x 6.22	Master Carton Wgt: 26.9 lbs (12.2 kg)
Size in mm: 45 x 158	Warranty (Years): 5
CRI (Ra): >70	Luminous efficacy: 95-110 lm/W
LED Type: Epistar SMD2835 x 98 pieces	Working Temperature: -4°F to +113°F (-20°C to +45°C)
Beam Angle: 360°	Certification: UL, cUL
IP rating: 64	Net Weight: 0.35 lbs (0.16 kg)
Power Factor (PF): >0.90	Notes: Old ballast should be removed as an over-voltage may occur.

Item Code:
PGL-61243 - 3000K
PGL-61244 - 4000K
PGL-61245 - 5000K
PGL-61246 - 6000K



Compares to 100W incandescent, 30W CFL

Plug-in Lights

15W 1500 LUMENS 4000K G24Q 4 Pin 100-277v AC UL

Lumens: 1500	Fixture Color: White
Watts: 15	Fixture Material: PC/Aluminum
Light Color (Kelvin): 4000	Lifetime (Hours): 50,000
Voltage: 100-277V AC	Master Carton Quantity: 50
Base Type: G24Q - 4 Pin	M Carton Size: 13.8" x 11.8" x 11.8"
Size in Inches: 2.16 x 6.1	(350mm x 300mm x 300mm)
Size in mm: 55 x 155	Master Carton Wgt: 32.6 lbs (14.8 kg)
CRI (Ra): >70	Warranty (Years): 5
LED Type: Epistar SMD2835 x 120 pieces	Luminous efficacy: 100-115 lm/W
Beam Angle: 360°	Working Temperature: -4°F to +113°F (-20°C to +45°C)
IP rating: 64	Certification: UL, cUL
Power Factor (PF): >0.90	Net Weight: 0.48 lbs (0.22 kg)
Notes: Old ballast should be removed as an over-voltage may occur.	

Item Code: PGL-61544



Compares to 120W incandescent,
40W CFL

Note: New 20W version available.
Please see website for more details

WIRING CONFIGURATION FOR G24 PLUG-IN LAMPS

INSTALLATION INSTRUCTIONS

- ◆ Before fitting this LED Lamp we recommend that you remove the ballast regardless of whether it is a magnetic or electronic type. The electronic version could damage the lamp and the magnetic version will continue to waste power.
- ◆ Ensure the AC supply is disconnected.
- ◆ Remove the Black & White supply side feed from the ballast and remove the wires from the socket to the ballast.
- ◆ Connect the Black & White wires directly to the wires from the socket such that the ballast is no longer in the circuit.

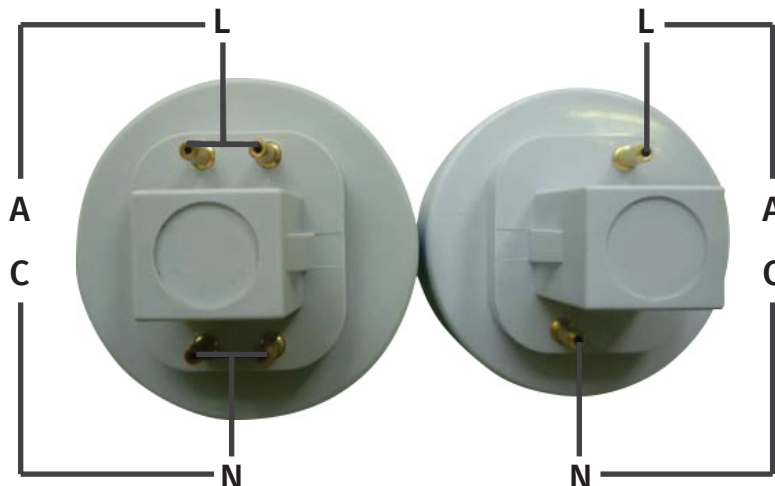

High Lumen Bulbs

30W 2700 LUMENS 6000K E26 with E39 mogul adapter	
Lumens: 2700	Fixture Color: White
Watts: 30	Fixture Material: PC/Aluminum
Light Color (Kelvin): 6000K	Lifetime (Hours): >40,000
Voltage: 100-300V AC	Master Carton Quantity: 20
Base Type: E26 Medium (E39 Mogul adapter)	M Carton Size: 16.93" x 13.58" x 8.27" (430mm x 345mm x 210mm)
PGZ-42739 included)	Master Carton Wgt: 19.72 lbs (8.94 kg)
Size in Inches: 3.15 x 5.87	Warranty (Years): 3
Size in mm: 80 x 149	Luminous efficacy: 90 lm/W
CRI (Ra): >75	Working Temperature: +14° F to +122° F (-10° C to +50° C)
LED Type: 56 x Epistar SMD2835	Certification: UL, CE, RoHS
Beam Angle: 210°	Net Weight: 0.88 lbs (400 g)
IP rating: 34	Notes: 2700K-6500K available
Power Factor (PF): >0.9	

Item Code: BLB-43608



Compares to a 100W MH/HPS/HID, 60W CFL, 200W Incandescent

40W 3300 LUMENS 6000K E26 with E39 mogul adapter	
Lumens: 3300	Fixture Color: White
Watts: 40	Fixture Material: PC/Aluminum
Light Color (Kelvin): 6000	Lifetime (Hours): >40,000
Voltage: 100-300V AC	Master Carton Quantity: 20
Base Type: E26 Medium (E39 Mogul adapter)	M Carton Size: 16.93" x 13.58" x 8.27" (430mm x 345mm x 210mm)
PGZ-42739 included)	Master Carton Wgt: 22.11 lbs (10.02 kg)
Size in Inches: 3.15 x 5.87	Warranty (Years): 3
Size in mm: 80 x 149	Luminous efficacy: 83 lm/W
CRI (Ra): >75	Working Temperature: +14° F to +122° F (-10° C to +50° C)
LED Type: 49 x Epistar SMD3030	Certification: UL, CE, RoHS
Beam Angle: 210°	Net Weight: 0.88 lbs (400 g)
IP rating: 34	Notes: 2700K-6500K available
Power Factor (PF): >0.9	

Item Code: BLB-44670



Compares to a 120W MH/HPS/HID, 80W CFL, 250W Incandescent

High Lumen Bulbs

50W 3700 LUMENS 6000K E26 with E39 mogul adapter

Lumens: 3700	Fixture Color: White
Watts: 50	Fixture Material: PC/Aluminum
Light Color (Kelvin): 6000	Lifetime (Hours): >40,000
Voltage: 100-300V AC	Master Carton Quantity: 20
Base Type: E26 Medium (E39 Mogul adapter PGZ-42739 included)	M Carton Size: 16.93" x 13.58" x 8.27" (430mm x 345mm x 210mm)
Size in Inches: 3.15 x 5.87	Master Carton Wgt: 22.11 lbs (10.02 kg)
Size in mm: 80 x 149	Warranty (Years): 3
CRI (Ra): >75	Luminous efficacy: 74 lm/W
LED Type: 56 x Epistar SMD3030	Working Temperature: +14°F to +122°F (-10°C to +50°C)
Beam Angle: 210°	Certification: UL, CE, RoHS
IP rating: 34	Net Weight: 0.88 lbs (400 g)
Power Factor (PF): >0.9	Notes: 2700K-6500K available

Item Code: **BLB-45606**



Compares to a 175W MH/HPS/HID,
100W CFL



EXXON Lighting Corporation



Tube & Panel Lights

18W 1900 LUMENS 4100K T5 4 ft. Fitting UL

Lumens: 1900	Fixture Color: White
Watts: 18	Fixture Material: Aluminum - PC
Light Color (Kelvin): 4100K	Lifetime (Hours): >50,000
Milky Cover	Master Carton Quantity: 20
Voltage: 120-277V AC	Master Carton Size: 24.4 "x 16.5" x 16.5" (620 x 420 x 420mm)
Base Type: G13	Master Carton Wgt: 20.9 lbs (9.5 kg)
Size in Inches: 24 x 7.1 (pin to pin)	Warranty (Years): 5
Size in mm: 610 x 180.6 (pin to pin)	Luminous efficacy: 110 lm/W
CRI (Ra): >80	Working Temperature: -4°F to +122°F (-20°C to +50°C)
LED Type: Epistar SMD 2835 x120	Certification: UL, CE, RoHS, DLC
Beam Angle: 120°	Net Weight: 0.9 lbs (0.41 kg)
IP rating: 44	Compares to a 32W Fluorescent (All recommendations are subject to individual configurations which affect final results. This statement does not take into account the variance of ceiling height, cone angle, Kelvin & many other factors.)
Power Factor (PF): 0.95	

Item Code: TRF-51894



18W 1900 lumens 5000K 4 ft. tube UL DLC

Lumens: 1900	Fixture Color: Frosted
Watts: 18	Fixture Material: PC/Aluminum
Light Color (Kelvin): 3000, 5000, 6000	Lifetime (Hours): 50,000
	Master Carton Quantity: 25
Voltage: 100-277V AC	Master Carton Size: 49" x 7.5" x 7.7" (1240mm x 190mm x 195mm)
Base Type: G13	Master Carton Wgt: 24 lbs (10.9 kg)
Size in Inches: 48 x 1.02	Warranty (Years): 5
Size in mm: 1220 x 26	Luminous efficacy: 103 lm/W
CRI (Ra): >80	Working Temperature: -4°F to +122°F (-20°C to +50°C)
LED Type: 144 x Epistar 2835	Certification: UL, DLC
Beam Angle: 120°	Net Weight: 0.7 lbs (0.32 kg)
IP rating: Damp location	Notes: Compatible with electronic and magnetic ballasts
Power Factor (PF): >0.9	

Item Code: TRF-61850



Compares to a 32W fluorescent

Tube & Panel Lights

20W 2200 lumens 4 ft. tubeS UL DLC

Lumens: 2200	Fixture Color: White- Clear or Frosted
Watts: 20	Fixture Material: PC/Aluminum
Light Color (Kelvin): 3000, 5000, 6000	Lifetime (Hours): 50,000
	Master Carton Quantity: 25
Voltage: 100-277V AC	Master Carton Size: 49" x 7.5" x 7.7"
Base Type: 2 Pin T8 G13 (rotatable)	(1240mm x 190mm x 195mm)
	Master Carton Wgt: 24 lbs (10.9 kg)
Size in Inches: 48 x 1	Warranty (Years): 3
Size in mm: 1220 x 25	Luminous efficacy: 110-132 lm/W
CRI (Ra): >85	Working Temperature: -4°F to +149°F (-20°C to +65°C)
LED Type: Epistar SMD2835	Certification: UL, DLC
Beam Angle: 160°	Net Weight: 0.88 lbs (400 g)
IP rating: 20	Notes: Rotatable end caps
Power Factor (PF): >0.95	

Item Code:

- TRF-48230 (3000K, 2200lm Clear)
- TRF-64827 (3500K, 2200lm Frosted)
- TRF-44292 (5000K, 2200lm Clear)
- TRF-48251 (5000K, 2200lm Frosted)
- TRF-48260 (6000K, 2200lm Clear)
- TRF-48261 (6000K, 2200lm Frosted)
- TRF-54827 (3100K, 2640lm Frosted)



Others available for quotation upon request. See web site for details.

27W 2900 LUMENS 5000K R17d CLEAR 6 ft. tube UL

Lumens: 2900	Fixture Color: White
Watts: 27	Fixture Material: PC/Aluminum
Light Color (Kelvin): 5000	Lifetime (Hours): 50,000
Voltage: 100-277V AC	Master Carton Quantity: 20
Base Type: R17D	Master Carton Size: 72" x 8.7" x 7.9"
	(1830mm x 220mm x 200mm)
Size in Inches: 71 x 1	Master Carton Wgt: 32.6 lbs (14.8 kg)
Size in mm: 1800 x 26	Warranty (Years): 3
CRI (Ra): >80	Luminous efficacy: 107 lm/W
LED Type: SMD2835	Working Temperature: -4°F to +113°F (-20°C to +45°C)
Beam Angle: 120°	Certification: UL
IP rating: 20	Net Weight: 1.2 lbs (0.55 kg)
Power Factor (PF): >0.92	Notes: Double end powered

Item Code: TRF-62705



EXXON Lighting Corporation



Tube & Panel Lights

40W 4800lm 5000K FA8 Base Clear 8 ft. Tube UL	
Lumens: 4800	Master Carton Quantity: 20
Watts: 40	Master Carton Size:
Light Color (Kelvin): 5000 (Clear)	Master Carton Wgt:
Voltage: 100-277V AC	LED Type: SMD2835
Base Type: FA8	Power Factor (PF): 0.90
Size in Inches: 96	Warranty (Years): 5
Size in mm: 2438	Luminous efficacy: 120 lm/W
CRI (Ra): >80	Working Temperature: -4 to +113
Beam Angle: 120°	(-20 to +45)
IP rating:	Certification: UL, RoHS
Fixture Color:	Net Weight:
Fixture Material:	Notes: Type B (Direct voltage connection - no ballast)
Lifetime (Hours):	

Item Codes: TRF-70402-F5-C



40W 4600lm 5000K R17D (HO) Base Frosted 8 ft. Tube UL	
Lumens: 4600	Lifetime (Hours):
Watts: 40	Master Carton Quantity: 20
Light Color (Kelvin): 5000 (Frosted)	Master Carton Size:
	Master Carton Wgt:
Voltage: 100-277V AC	LED Type: SMD2835
Base Type: R17D (HO)	Power Factor (PF): 0.90
Size in Inches: 96	Warranty (Years): 5
Size in mm: 2438	Luminous efficacy: 115 lm/W
CRI (Ra): >80	Working Temperature: -4 to +113
Beam Angle: 120°	(-20 to +45)
IP rating:	Certification: UL, RoHS
Fixture Color:	Net Weight:
Fixture Material:	Notes: Type B (Direct voltage connection - no ballast)

Item Codes: TRF-70402-R5-F



Tube & Panel Lights

40W 4800lm 5000K R17D (HO) Base Clear 8 ft. Tube UL

Lumens: 4800	Master Carton Quantity: 20
Watts: 40	Master Carton Size:
Light Color (Kelvin): 5000 (Clear)	Master Carton Wgt:
Voltage: 100-277V AC	LED Type: SMD2835
Base Type: R17D (HO)	Power Factor (PF): 0.90
Size in Inches: 96	Warranty (Years): 5
Size in mm: 2438	Luminous efficacy: 120 lm/W
CRI (Ra): >80	Working Temperature: -4 to +113
Beam Angle: 120°	(-20 to +45)
IP rating:	Certification: UL, RoHS
Fixture Color:	Net Weight:
Fixture Material:	Notes: Type B (Direct voltage connection - no ballast)
Lifetime (Hours):	

Item Codes: TRF-70402-R5-C



40W 4600lm 5000K FA8 Base Frosted 8 ft. Tube UL

Lumens: 4600	Fixture Material:
Watts: 40	Master Carton Quantity: 20
Light Color (Kelvin): 5000 (Frosted)	Master Carton Size:
	Master Carton Wgt:
Voltage: 100-277V AC	LED Type: SMD2835
Base Type: FA8	Power Factor (PF): 0.90
Size in Inches: 96	Warranty (Years): 5
Size in mm: 2438	Luminous efficacy: 82 lm/W
CRI (Ra): >80	Working Temperature: -4 to +113
Beam Angle: 120°	(-20 to +45)
IP rating:	Certification: UL, RoHS
Fixture Color:	Net Weight:
Lifetime (Hours):	Notes: Type B (Direct voltage connection - no ballast)

Item Codes: TRF-70402-F5-F



EXXON Lighting Corporation



Tube & Panel Lights

36W 3950 lumens 100-277V AC 8 ft. tube	
Lumens: 3950	Fixture Color: White - Clear or Frosted
Watts: 36	Fixture Material: PC/Aluminum
Light Color (Kelvin): 5000	Lifetime (Hours): 50,000
Voltage: 100-277V AC	Master Carton Quantity: 20
Base Type: FA8	Master Carton Size:
Size in Inches: 96 x 1	Master Carton Wgt: 41.6 lbs (18.9 kg)
Size in mm: 2440 x 25	Warranty (Years): 3
CRI (Ra): >85	Luminous efficacy: 105 lm/W
LED Type: Epistar SMD2835	Working Temperature: -4°F to +149°F (-20°C to +65°C)
Beam Angle: 180°	Certification:
IP rating:	Net Weight:
Power Factor (PF): >0.95	Notes:

Item Codes:

- TRF-40872 (5000K, 3950lm Clear)**
- TRF-48351 (5000K, 3780lm Frosted)**
- TRF-66536 (6500K, 3780lm Frosted)**



Others available for quotation upon request.

36W 3950 LUMENS 5000K R17D (H0) Base 8 ft. tube	
Lumens: 3950	Fixture Color: White
Watts: 36	Fixture Material: PC/Aluminum
Light Color (Kelvin): 5000	Lifetime (Hours): 50,000
Voltage: 100-277V AC	Master Carton Quantity: 20
Base Type: R17D (H0)	Master Carton Size: 96.5" x 7.5" x 9.5" (2450 x 190 x 240mm)
Size in Inches: 96 x 1	Master Carton Wgt: 41.6 lbs (18.9 kg)
Size in mm: 2373 x 25	Warranty (Years): 3
CRI (Ra): >85	Luminous efficacy: 110 lm/W
LED Type: Epistar SMD2835	Working Temperature: -22°F to +140°F (-30°C to +60°C)
Beam Angle: 180°	Certification: UL, CE, RoHS
IP rating: 22	Net Weight: 1.65 lbs (0.75 kg)
Power Factor (PF): >97	Notes: Double end powered - see Installation Sheet before fitting.

Item Code:

- TRF-50819 - Clear**
- TRF-60817 - Frosted**



Tube & Panel Lights

40W 4200 LUMENS 5000K 4 ft. Tube LIGHT

Lumens: 4200	Fixture Color:
Watts: 40	Fixture Material: Aluminum - PC
Light Color (Kelvin): 5000	Lifetime (Hours): >35,000
Voltage: 100-277V AC (24V DC available)	Master Carton Quantity: 25
Base Type: G13	M Carton Size: 49" x 7.5" x 7.7" (1240mm x 190mm x 195mm)
Size in Inches: Dia. 1.18 x L 47.16 (w/o pin)	Master Carton Wgt: 24 lbs (10.9 kg)
Size in mm: Dia. 30 x L 1198 (without pin)	Warranty (Years): 3
CRI (Ra):	Luminous efficacy:
LED Type: 480 x Epistar	Working Temperature: 158°F @ Ta = 77°F (70°C @ Ta = 25°C)
Beam Angle: 360°	Certification: CE, RoHS, DLC
IP rating:	Net Weight: 0.84 lbs (0.38 kg)
Power Factor (PF):	Notes: 2700-3800K and 5500-6700K available.

Item Code: TRF-57941



Compares to an 80-100W CFL

20W 1575 LUMENS 4000K panel (1 ft. x 2 ft.)

Lumens: 1575	Fixture Color: White/Silver
Watts: 20	Fixture Material: Aluminum + PMMA
Light Color (Kelvin): 4000 (also available in 3000 & 6000)	Lifetime (Hours): >30,000
Voltage: 86-265V AC	Master Carton Quantity: 5
Base Type:	Carton Size: 14.6" x 25.6" x 9.65" (370mm x 675mm x 245mm)
Size in Inches: 11.61 x 23.43 x 0.35	Carton Weight: 30.9 lbs (14 kg)
Size in mm: 295 x 595 x 9	Warranty (Years): 3
CRI (Ra): >78	Luminous efficacy: 77 lm/W
LED Type: Epistar SMD4014 (100 pieces)	Working Temperature: -13°F to +149°F (-25°C to +65°C)
Beam Angle:	Certification:
IP rating: 44	Net Weight:
Power Factor (PF): 0.95	Notes: Can be Ceiling mounted, Suspended or Surface mounted

Item Code: TRF-40296



Many different configurations for LED Panel Lights are available, including but not limited to:

1 ft. x 1 ft., 20W (1400, 1500 & 1600 lumens available)
 1 ft. x 2 ft. TRF-40296 (shown above)
 2 ft. x 2 ft., TRF-44247 40W (2800, 2900 & 3000 lumens available)
 1 ft. x 4 ft., 40W (2800, 2900 & 3000 lumens available)
 2 ft. x 4 ft., TRF-47208 80W (5500, 5800 & 6200 lumens available)
 All available in a range of colors from 2800K to 6500K, all operate on 86-277V AC

Pool Lights

6W Color Changing Pool Light 12V AC	
Lumens: None	Fixture Color: White
Watts: 6	Lifetime (Hours): 60000
Light Color (Kelvin): RGB	Master Carton Quantity: None
Voltage: 12V	Master Carton Size: None
Base Type: n/a	Master Carton Weight: None
Size in Inches: 3.9	LED Type: None
Size in mm: 100	Power Factor (PF): None
CRI (Ra): None	Fixture Material: None
Beam Angle: None	Warranty (Years): None
IP rating: 68	Luminous Efficacy: None
	Working Temperature °F (°C): None
	Certification: None
	Net Weight: None
	Notes: None

Item Code: PNL-70071



18W Color Changing Pool Light 12V AC	
Lumens: None	Fixture Color: None
Watts: 18	Lifetime (Hours): None
Light Color (Kelvin): RGB Color Changing	Master Carton Quantity: None
Voltage: 12V	Master Carton Size: None
Base Type: n/a	Master Carton Weight: None
Size in Inches: None	LED Type: None
Size in mm: None	Power Factor (PF): None
CRI (Ra): None	Fixture Material: None
Beam Angle: None	Warranty (Years): None
IP rating: None	Luminous Efficacy: None
	Working Temperature °F (°C): None
	Certification: None
	Net Weight: None
	Notes: None

Item Code: PNL-70181

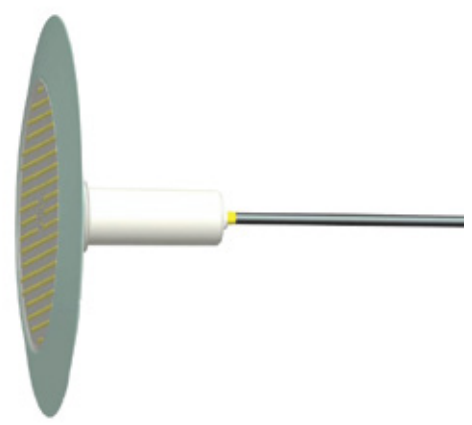

Pool Lights

2W 180 LUMENS 6000K Step Light

Lumens: 180	Fixture Color: Stainless	
Watts: 2	Fixture Material: Single piece of engineering plastic, diamond patterned anti-glare face cover with Stainless Steel cover plate.	
Light Color (Kelvin): 6000		
Voltage: 100-277V AC	Lifetime (Hours): >50,000	
Base Type: 2 wire		
Size in Inches: 5.31 x 2.95 x 1.65	Master Carton Quantity: 20	
Size in mm: 135 x 75 x 45	Master Carton Size:	
CRI (Ra):	Master Carton Weight:	
LED Type:	Warranty (Years): 3	
Beam Angle:	Luminous efficacy: 90 lm/W	
IP rating: 65	Working Temperature: -22°F to +113°F (-30°C to +45°C)	
Power Factor (PF):		Certification: CE, RoHS
		Net Weight: 0.36 lbs (163 g)

Item Code: PNL-41277



18W 1620 LUMENS AUTOColor Changing Pond Light 24V DC

Lumens: 1620	Fixture Color: Stainless Steel
Watts: 18	Fixture Material: Stainless Steel 304 plus tempered glass
Light Color (Kelvin): RGB Changing	
Voltage: 24V DC	Lifetime (Hours): >50,000
Base Type: 4 Wire with OD of 6mm - length to order up to 100ft.	Master Carton Quantity:
	Master Carton Size:
Size in Inches: 7.6 x 2.75 Plus Bracket	Master Carton Weight:
Bracket	Warranty (Years): 3
	Luminous efficacy: 90 lm/W
Size in mm: 193 x 70 Plus Bracket	Working Temperature: -4°F to +113°F (-20°C to +45°C)
CRI (Ra): >75	Certification: CCC, CE, Energy Star, EMC, LVD, RoHS, VDE
LED Type: 18 x 1W Epileds	
Beam Angle: 45°	Net Wgt: 2.88 lbs (1.3 kg) plus wire wgt
IP rating: 68	
Power Factor (PF): 0.9	Notes: A beautiful pool or pond light with auto color changing

Item Code: PNL-31863



EXXON Lighting Corporation



Pool Lights

18W 1620 LUMENS Auto Color Changing Pond Light 12V AC	
Lumens: 1620	Fixture Color: Stainless
Watts: 18	Fixture Material: Stainless Steel 304
Light Color (Kelvin): RGB Changing	plus tempered glass
Voltage: 12V AC	Lifetime (Hours): >50,000
Base Type: 3 wire	Master Carton Quantity:
Size in Inches: 10.25 x 1.4	Master Carton Size:
Size in mm: 261 x 35	Master Carton Weight:
CRI (Ra): >75	Warranty (Years): 3
LED Type: 18 X 1W Epileds	Luminous efficacy:
Beam Angle: 160°	Working Temperature: -4°F to
IP rating: 68	+113°F (-20°C to +45°C)
Power Factor (PF): 0.9	Certification: CCC, CE, Energy Star, EMC, LVD, RoHS, VDE
	Net Weight: 2.88 lbs (1.3 kg)
Notes: A beautiful pool or pond light with auto color changing	

Item Code: PNL-37128



80W 24V DC output Waterproof Power Supply	
Lumens:	Fixture Color:
Watts: 80	Fixture Material:
Light Color (Kelvin):	Lifetime (Hours):
Voltage: Input 80-250V AC, Output 3.3A, 24V DC +/- 0.5V	Master Carton Quantity:
Battery Type:	Master Carton Weight:
Solar Panel:	Warranty (Years):
Size in Inches: 2.76 x 7.1	Working Temperature:
Size in mm: 70 x 180	Certification:-
CRI (Ra):	Net Weight:
Beam Angle:	Notes:
IP rating: 67	

Item Code: PNL-36291



Pool Lights

Remote Controller System	
Lumens:	Fixture Color:
Watts:	Fixture Material:
Light Color (Kelvin):	Lifetime (Hours):
Voltage: Input 12-24V DC, Output 24A	Master Carton Quantity:
Battery Type: 12V, 40 mAh (A23) battery (not included)	Master Carton Weight:
Solar Panel:	Warranty (Years):
Size in Inches:	Working Temperature: -4°F to +140°F (-20 °C to +60°C)
Size in mm:	Certification:-
CRI (Ra):	Net Weight: 0.35 lbs (160 g)
Beam Angle:	Notes:
IP rating:	

Item Code: PNL-39261



18W 1500 LUMENS Auto Color Changing Fountain Light 24V AC	
Lumens: 1500	Fixture Color: Stainless Steel
Watts: 18	Fixture Material: Stainless Steel 304 plus tempered glass
Light Color (Kelvin): RGB Changing	Lifetime (Hours): >50,000
Voltage: 24V AC	Master Carton Quantity:
Base Type: 3 wire	Master Carton Size:
Size in Inches: 8 x 3.25 (center hole = 2.25)	Master Carton Weight:
Size in mm: 203 x 82 (center hole - 57)	Warranty (Years): 3
CRI (Ra): >75	Luminous efficacy: 80 lm/W
LED Type: 18 x Epileds	Working Temperature: -4°F to +113°F (-20°C to +45°C)
Beam Angle: 60°	Certification: CE, RoHS
IP rating: 68	Net Weight: 4.56 lbs (2.06 kg)
Power Factor (PF): 0.9	Notes:

Item Code: PNL-35346



EXXON Lighting Corporation



Accessories

7 LED Rechargeable, 3 Ni-MH, USDA

Six white super light LEDs on side, plus one white light LED on the head as Flashlight

Size: 6.65" x 1.2" x 0.73" (169mm x 30.5mm x 18.5mm)

Magnet on the clip (to attach to a metal surface)

Powered by 3 x AAA 600 mA 1.2V Ni-MH Batteries (included)

Working time: ~2.5 Hours

Charging time: 5-6 Hours

12V DC car charger and USB charger cable included

Packed in 50s (2 inner cartons) 15.77 lbs (7.15 kg) 19.5" x 11" x 16"
(410mm x 370mm x 310mm)

Blister Packed

Red In Color

Item Code: WKL-30639



7 LED Non-Rechargeable, 3 AAA, USDA

Six white super light LEDs on side, plus one white light LED on the head as Flashlight

Unit Size: 6.45" x 0.94" x 1.22" (164mm x 24mm x 31mm)

Material: ABS with rubber coated surface.

Powered by 3 AAA alkaline batteries (Not Included)

Magnet on the clip (to attach to a metal surface)

Boxed in 200's (2 inner cartons) 29.8 lbs (13.53 kg) 14.5" x 12.5" x 16"
(410mm x 370mm x 310mm)

White Boxed

Item Code: WKL-30675





800-769-3221



866-619-0925



SALES@EXXONLIGHTING.COM



WWW.EXXONLIGHTING.COM